

Section 13

Sentry System 2100-950 with STC 2100 Series Scanners (Work Procedure 10)

Table of Contents	i
-------------------------	---

Work Procedure 10

<i>Chapter Overview</i>	1
Purpose.....	1
Scope.....	1
Bi-weekly Maintenance	2
Tools Needed	2
Task List.....	3
Visual Inspection	3
Voltage Checks	4
Lens Cleaning	5
Lens Cleaning Procedure	6
Operational Test.....	7
Monthly Maintenance	9
Equipment Needed.....	9
Transducer Height.....	9
System Calibration.....	9
Quarterly Maintenance.....	13
Equipment Needed.....	13
Task List.....	14
Scanner Alignment.....	14
Checking the Track Circuit.....	19
Shutter door linkage lubrication.....	20

System Configuration

<i>Chapter Overview</i>	21
Purpose.....	21
Scope.....	21
Functional Description.....	23

Continued on next page

Section 13, Continued

System Configuration (continued)

System Overview	22
System Description	22
Defect Reporting	22
CSX Configuration	22
History Files	23
Operating Environment	23
Theory of Operation	23
Component Descriptions	24
Overview	24
Scanners	24
Scanner Mounts	24
Scanner Output	25
Transducers	25
Transducer Operation	26
Transducer Types	26
Auxiliary-Alarm Detectors	27

Bungalow Components

Overview	28
Components	28
Electronics Enclosure	28
Description	29
Keypad	30
LCD	31
Status LEDs	31
Communications Board	32
CPU Board	33
Talker Board	33
Interface Module	34
Description	34
Interface Board	34
Power Indication Board	35
Distribution Board	36
Fuse Panel	36
Presence Detector Module	37
Description	37
LED	37

Continued on next page

Section 13, Continued

Bungalow Components, continued

Power Supply Module.....	38
Description.....	38
Outputs.....	38
Power Supply Board	38
Status LEDs	39
Power Converter and Battery Charger	40
Modem Module.....	41
Description.....	41
Status LEDs	41
Radio Panel.....	42
Description.....	42
RF Transmitter.....	42
Squelch Interface	42
Shielded Temperature Probe.....	43
Description.....	43
Operation.....	43

Troubleshooting

Chapter Overview	44
Purpose.....	44
Scope.....	44
Standard Troubleshooting Procedure.....	45
Introduction.....	45
Standard Procedure	45
Troubleshooting	46
Problem and Possible Causes.....	46
Messages	46
LEDs	46
Integrity Failures.....	47
Other Problems	49
Transducer Problems	51

Continued on next page

Section 13, Continued

Troubleshooting, continued

Float Voltage Adjustment	52
Overview	52
Procedure	52
Train Movement.....	54
Process	54
Arrival Message	55
Real-Time Messages	55
Post-Train Messages	55

Computer Interface

Chapter Overview	56
Purpose.....	56
Scope.....	56
Main Menu.....	57
Communication Connection	57
Accessing the Main Menu	57
Options.....	57
Exiting the Main Menu	58
Train Summary Report	59
Overview.....	59
Accessing the Train Summary	59
Report Layout	60
Information Fields.....	60
Train Detail Report	62
Overview.....	62
Accessing the Train Detail.....	62
Report Layout	63
Information Fields.....	63
Exception Summary Report	66
Overview.....	66
Accessing the Exception Summary	66
Report Layout	66
Information Fields.....	67

Continued on next page

Section 13, Continued

Computer Interface, continued

Exception Detail Report.....	68
Overview.....	68
Accessing the Exception Detail	68
Abbreviated Exception Detail.....	68
Report Layout	68
Information Fields.....	69

Appendixes

System Alarm Definitions.....	A-1
Integrity Failure Definitions	B-1

Work Procedure

Number 10

Chapter Overview

Purpose This chapter provides maintenance procedures as outlined in Rule 27.0 for the Sentry System 2100-950 with STC 2100-series scanners.

Scope Topics covered in this chapter include these maintenance procedures:

- Bi-weekly
 - Monthly
 - Quarterly
-

Bi-weekly Maintenance

Tools Needed The following equipment is needed to perform bi-weekly maintenance:

- Fluke 27, 87, or equivalent
- Calibrated Heat Source
- Torque wrench and appropriate sockets
- Laptop computer or Personal Data Assistant (PDA) – optional
- Scanner Lens Cleaning kit (#2100-530)
- Bottle of clean water
- Appropriate hand tools



Figure 13-1 Fluke meter, Laptop computer, and hand tools.

Figure 13-2 Scanner lens cleaning kit, bottle with clean water.



Continued on next page

Bi-weekly Maintenance, Continued

Task List The following tasks are performed during bi-weekly maintenance:

- Visual inspection
 - Voltage checks
 - Lens cleaning
 - Operational tests
-

Visual Inspection Follow these inspection steps every two weeks:

Step	Action
1	Inspect; then, if necessary, tighten, and/or replace loose bolts and broken parts on the: <ul style="list-style-type: none">• Transducers• Scanner bases• Track circuit connections• Dragger• Junction boxes
2	Inspect all ground rods and connections; then, if necessary, replace or repair them.
3	Inspect and replace any badly damaged paddles on the dragger.
4	Remove debris or obstructions from the dragger.
5	Inspect the dragger switch gaskets to ensure that water is not getting into the switch contact.



Figure 13-3 Inspect the dragger switch gasket.

Continued on next page

Bi-weekly Maintenance, Continued

Visual Inspection , continued

Step	Action
6	Ensure ballast/debris is at least four inches from bottom of scanner base.
7	Verify that the correct date and time are displayed on the Sentry System LCD panel in the bungalow. If data and/or time indications are incorrect, refer to On-site System Setup procedures in the Southern Technologies Corporation <i>Model 2100-950 Sentry System User's Guide for CSX</i> .

Figure 13-4 Verify correct date and time on the Sentry System LCD panel.



Voltage Checks Every two weeks, check Sentry System voltages by doing the following:

1. Check battery and AC power input voltages with a multi-meter. Record values in the Sentry System logbook.
2. Ensure the following Sentry System LEDs are indicating correctly:

Module	LED	Indication
Power Supply	115 VAC	On steady
	24 VDC	On steady
Interface Module	120 VAC	On steady
	+12 VDC	On steady
Communications Module	+5 VDC	On steady
	-12 VDC	On steady
	COP	Off

Continued on next page

Figure 13-5 Checking for correct battery voltage.



Lens Cleaning

Probably the single most important item of continuing maintenance for the Series 2100 scanner is lens cleanliness. The scanner has a protective shutter that prevents the entry of moisture and dust during periods of inactivity, but the lens must be exposed during scanning operations.

Over time, this will result in a buildup of a film on the scanner lens. This film will reduce the amount of infrared light energy that the lens can collect, reducing output from the scanner.

Continued on next page

Bi-weekly Maintenance, Continued

Lens Cleaning Procedure

Perform the following procedure to clean scanner lenses:

Step	Action
1	Remove the cleaning wand and packet of chamois pads from the Scanner Lens Cleaning kit (#2100-530). Use provided o-rings to attach clean dry chamois pads on each end of the wand.
2	Saturate one pad with clean water.
3	On the Sentry System Analyzer, press the CAL key, then the YES key. Result: Scanner shutters open for approximately 3 minutes. CAUTION If scanner shutters close on the wand during the lens cleaning process, do NOT withdraw the wand. Go back to the bungalow and press the CAL key on the Sentry System Analyzer, followed by the YES key to gain an additional 3 minutes of shutter activation time.
4	Visually inspect scanner lenses for damage or accumulated dirt/debris. Use a flashlight if necessary.
5	Gently slide the wand with the saturated pad through the cover at approximately a 45° angle until you contact the lens.

Figure 13-6 Cleaning the scanner lens.



6	Slowly rotate the wand several times then withdraw it.
7	Reverse wand ends and insert the dry pad until it contacts the lens.
8	Slowly rotate the wand several times, then withdraw it and inspect the lens for cleanliness.
9	Check both pads and change, if dirty.

Continued on next page

Bi-weekly Maintenance, Continued

Lens Cleaning Procedure (continued)

Step	Action
10	Repeat the process on the opposite rail.
11	When you are finished cleaning the lenses, press the K2 key on the Sentry System Analyzer to close the shutters.

Operational Test/Manual Test

Southern Tech has developed a manual test mode that generates test trains to perform an Operational Test of the system. Follow the procedure below to test the defect detector and DED.

CAUTION

Ensure no trains will be arriving at the location within the next five minutes, so the system can run the test and timeout.

Step	Action
1	<p>Apply power to the Calibrated Heat Source. Place the Calibrated Heat Source in a shady area out of direct sunlight. The heat source is ready for use when the red LED on the unit cycles on and off (approximately 10 minutes).</p> <p>If the temperature is below 32° F (0° C) and you are using a Calibrated Heat Source for this test, place the SUBZERO switch on the heat source in the ON position.</p> <p style="text-align: center;">CAUTION Enabling the SUBZERO function above 32° F can damage the Calibrated Heat Source.</p>
2	On the radio, make an announcement that you are performing a test at the defect detector location.
3	Refer to pages 13-57 and 13-59 for instructions on connecting a laptop to the Sentry system. From the main menu, select the System Functions menu. From the System Functions menu, select Manual Test Mode.
4	The screen will ask “Do you want to proceed with Manual Test Mode?” Type Y for yes. The screen will show “Beginning Manual Test Mode.” You have about two minutes to perform your tests.
5	The test will start, shutters will open, and an arrival message will be transmitted.
6	After the arrival message, place a calibrated heat source on the scanner for approximately two seconds.

Continued on next page

Bi-weekly Maintenance, Continued

Operational Test (continued)

Step	Action
7	Remove the heat source and listen for the Real Time Message “You have a Defect”.
8	Activate the dragging equipment detector in one direction.
9	Wait for the Test Train to time out and verify announcement of the proper rail alarms and dragging equipment alarm.
10	Repeat test for the other rail, activating the dragger in the opposite direction.
11	On the laptop, return to the Main Menu and select A) Train Summary. Review the Train Summary report for any errors, integrity alarms, or any other unusual occurrences.
12	Before leaving the location: <ul style="list-style-type: none">• Remove power from the heat source and stow equipment properly.• Verify the radio is on and tuned to the correct frequency.• Cleanup the location.• Lock the location.

Monthly Maintenance

Equipment Needed

Monthly maintenance requires the following equipment:

- Calibrated Heat Source
- Small flathead screwdriver
- Ruler or tape measure



Figure 13-7 Calibrated Heat Source

Transducer Height

Prior to performing a system calibration, verify that all transducers are adjusted to a height of 1-5/8 to 1-3/4 inches from the top of the rail.

System Calibration

Complete all bi-weekly inspection requirements prior to beginning monthly maintenance. To calibrate the Sentry System, follow the procedure below.

Step	Action
1	DO NOT PERFORM A SYSTEM CALIBRATION IF AMBIENT TEMPERATURE IS ABOVE 90° F. IF YOU HAVE TO PERFORM A SYSTEM CALIBRATION WITH AMBIENT TEMPERATURE ABOVE 90° F, RETURN TO THE LOCATION AND RE-CALIBRATE THE SYSTEM WHEN TEMPERATURES DROP BELOW 90° F.

Continued on next page

Monthly Maintenance, Continued

System Calibration (continued)

Step	Action
2	<p>Apply power to the Calibrated Heat Source. Place the unit in a shady area out of direct sunlight. The heat source is ready for use when the red LED on the unit cycles on and off (approximately 10 minutes).</p> <p>If the temperature is below 32° F (0° C), place the SUBZERO switch on the heat source in the ON position.</p> <p style="text-align: center;">CAUTION Enabling the SUBZERO function above 32° F can damage the Calibrated Heat Source.</p>
3	<p>In the bungalow, press the CAL key on the Sentry System keypad.</p> <p>Result: CALIBRATE MODE – PROCEED is displayed on the LCD above the keypad.</p>
4	<p>Press the YES key on the keypad.</p> <p>Result: Shutters on the scanners open, and a direction (north) is displayed, along with a bearing in degrees.</p>

Figure 13-8
 Communications
 module LCD,
 LEDs, and
 keypad.

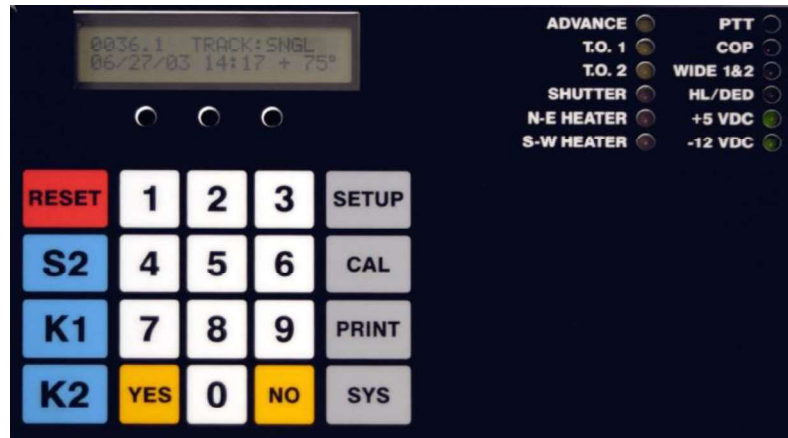

Continued on next page

Monthly Maintenance, Continued

System Calibration (continued)

Step	Action
5	Press the NO key on the keypad. Result: Numbers on the LCD are replaced by a cursor above one of the three adjustment potentiometers located immediately below the display.
6	Place the Calibrated Heat Source on the northern, or eastern rail scanner, depending upon track orientation. Ensure the red LED is cycling on and off to indicate the unit is ready for use. Result: A 3-digit number will cycle back and forth on the LCD.
7	Adjust the leftmost potentiometer until the peak value displayed is 180. Allow the display to stabilize between each adjustment.
8	When the peak value of 180 is consistently displayed, press YES on the keypad. Result: A direction (south) is displayed, along with a bearing in degrees.
9	Press NO on the keypad. Result: Numbers on the LCD are replaced by a cursor above one of the three adjustment potentiometers located immediately below the display.
10	Place the Calibrated Heat Source on the southern, or western rail scanner, depending upon track orientation. Result: A 3-digit number will cycle back and forth on the LCD.
11	Adjust the middle potentiometer until the peak value displayed is 180. Allow the display to stabilize between each adjustment.

Continued on next page

Monthly Maintenance, Continued

System Calibration (continued)

Step	Action
12	When the peak value of 180 is consistently displayed, press YES on the keypad. Result: System returns to normal operation with date and time displayed on the LCD.
13	Perform an operational test of the system.
14	Before leaving the location: <ul style="list-style-type: none">• Remove power from the heat source and stow equipment properly.• Verify the radio is on and tuned to the correct frequency.• Cleanup the location.• Lock the location.

Quarterly Maintenance

Equipment Needed

Quarterly maintenance requires the following equipment:

- Tape measure
- Alignment Fixture and Reflector Block (matched set)
- Hardwire shunt
- Appropriate hand tools



Figure 13-9 Alignment Fixture and Reflector Block, hardwire shunt, and tape measure.



Figure 13-10 Reflector Block mounted on scanner.

Continued on next page

Quarterly Maintenance, Continued

Task List

The following tasks are performed during quarterly maintenance:

- Scanner alignments
- Track circuit checks
- Shutter door linkage lubrication (annually)

Scanner Alignment

Complete all bi-weekly and monthly inspection requirements prior to beginning quarterly maintenance. To verify proper scanner alignment, follow the procedure below.

Step	Action
1	<p>Verify that scanners are correctly positioned between transducers by performing the following measurements. Transducers are positioned during installation and rarely need to be repositioned. Make any necessary adjustments.</p> <ul style="list-style-type: none"> • For transducers nearest the scanner, measure from the far side of the scanner track clamp to the center of the closest transducer mounting bolt. Correct distance is dependent upon rail size. <ul style="list-style-type: none"> 115 lb rail = 10-13/16 inches 132 lb rail = 11-5/16 inches 136 lb rail = 11-3/8 inches 141 lb rail = 11-5/8 inches • For transducers farthest from the scanner, measure from the far side of the scanner track clamp to the center of the closest transducer mounting bolt. Correct distance is dependent upon rail size. <ul style="list-style-type: none"> 115 lb rail = 34-13/16 inches 132 lb rail = 35-5/16 inches 136 lb rail = 35-3/8 inches 141 lb rail = 35-5/8 inches
2	On the outside of the rail, mark the midpoint between transducers TO1 and TO2.
3	Mark the center of the tie approximately 10-15 feet ahead of this midpoint.

Continued on next page

Quarterly Maintenance, Continued

Scanner Alignment (continued)

Step	Action
4	From this mark, measure to the midpoint between the transducers. Then measure the same distance on the opposite rail.

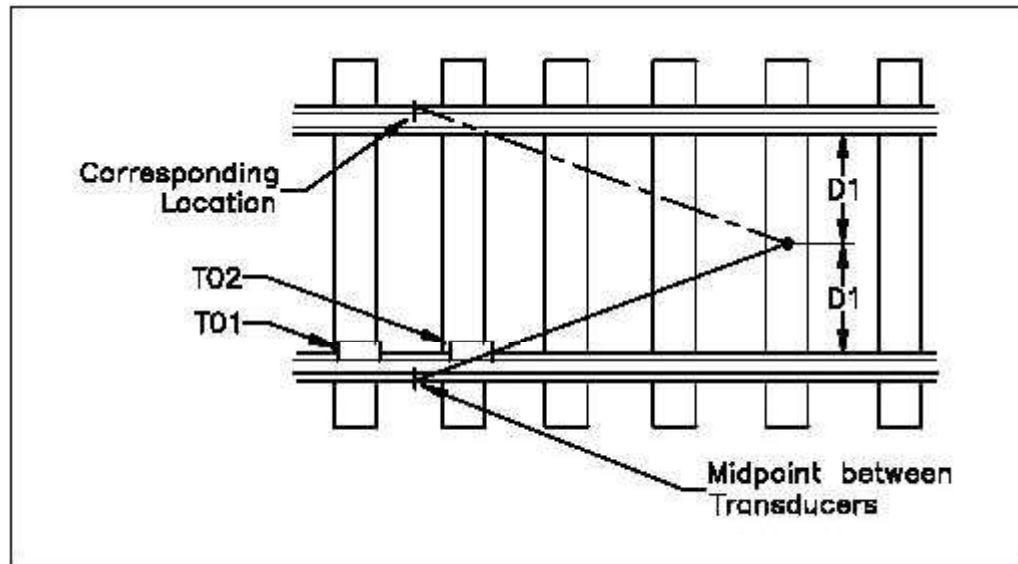

5	Mark the outside of the opposite rail at the measured distance. This mark should correspond with the mark between the two transducers.
6	Place the Alignment Fixture across both rails and adjust it so that the backside of the fiberglass channel is even with the two rail marks. NOTE Alignment Fixtures and Reflector Blocks are matched sets and cannot be interchanged with other fixtures. Ensure the Alignment Fixture fits snugly against the top and gauge of both rails.
7	Install the optical alignment target on the vertical alignment bar with the target sight tilted towards the bearing scanner.

Continued on next page

Quarterly Maintenance, Continued

Scanner Alignment (continued)

Step	Action
8	Install the reflector block in the top of the scanner cover with the sloping surface facing the target.

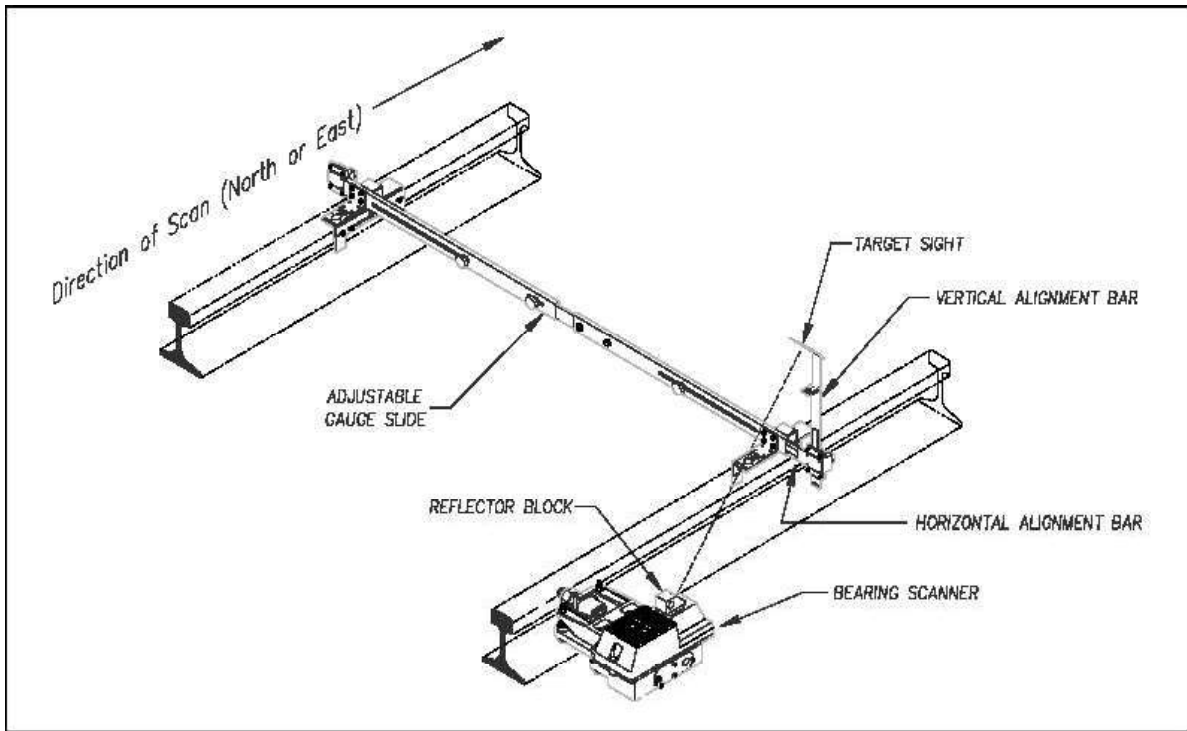

9	Extend the horizontal alignment bar to a point $7 \frac{1}{4}$ inches, plus or minus $\frac{1}{4}$ inch, from the gauge of the rail.
10	Extend the vertical alignment bar to a point 18 inches, plus or minus 1 inch, on the scale.
11	Look through the hole in the center of the target and note the relationship of the target crosshairs to the circle in the center of the reflector block. When the crosshairs are centered on the circle, alignment is correct.

Continued on next page

Quarterly Maintenance, Continued

Scanner Alignment (continued)



Figure 13-11 Alignment Fixture adjustments.

Step	Action
12	If horizontal adjustment is necessary, adjust the upper and lower nuts on the edge of the arm of the bearing scanner mount. Turn both upper nuts the same number of turns. Turn both lower nuts the same number of turns. Adjusting these four nuts causes the scanner to pivot about the two shock mounts under the rail. This adjustment moves the cross hairs (on the circle) to the right or left.

Figure 13-12 Looking through the Alignment Fixture peephole to determine proper scanner alignment.



Continued on next page

Quarterly Maintenance, Continued

Scanner Alignment (continued)

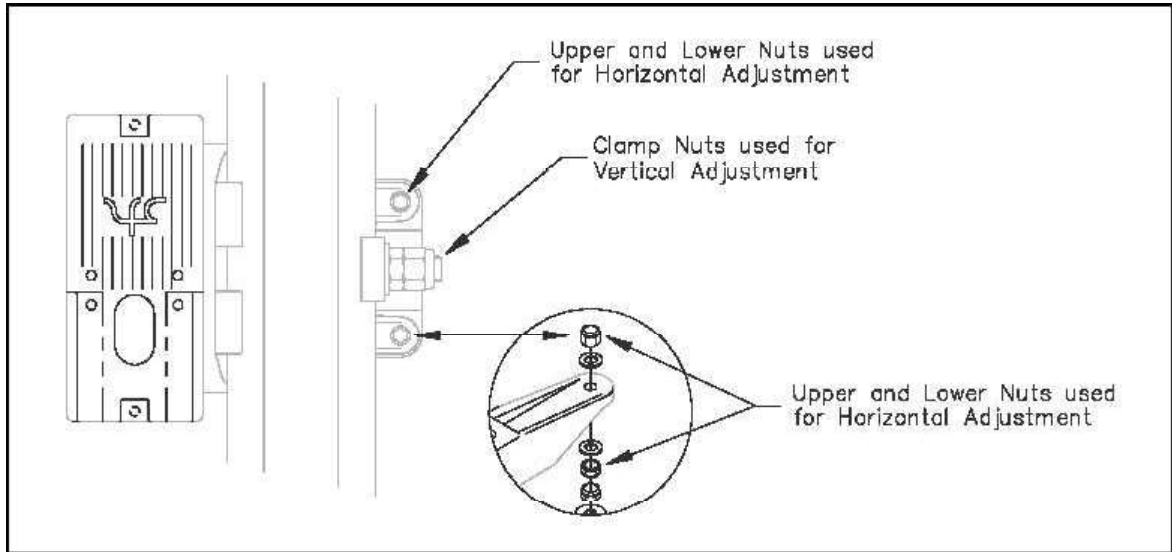

13	<p>If vertical adjustment is necessary:</p> <ul style="list-style-type: none"> • Loosen the two clamp nuts (on the side of the mount). • Slide the entire mount towards or away from the Alignment Fixture to raise or lower the circle in relation to the crosshairs. • Use a short-handle 1 ½ inch wrench to snug up the clamping nut and the locking nut. <p style="text-align: center;">CAUTION</p> <p>Use a torque wrench to tighten nuts to 50 foot-pounds. Do not exceed 50 foot-pounds of torque. Over-tightening can cause failure of the mount.</p>
14	Repeat steps 5 through 12 on the Southern, or Western rail.



Figure 13-12 Scanner mount bolts

Continued on next page

Quarterly Maintenance, Continued

Checking the Track Circuit

To check and adjust the track circuit, perform the following procedure:

Step	Action
1	<p>Place a hardwire shunt 100 feet from the track connections.</p> <p>NOTE</p> <p>The distance can be between 15 and 150 feet, depending upon conditions at the location. Check your site plans.</p> <p>Result: LED on the Sentry System Presence Detector module should illuminate.</p>

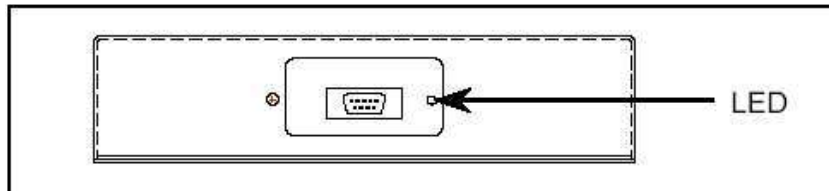

2	Using a small flathead screwdriver, turn potentiometer R24 (on the back of the Presence Detector module) until the LED (on the front of the Presence Detector module) goes out.
3	<p>Next, turn potentiometer R24 until the track circuit relay just picks up the pulse from the track circuit.</p> <p>The track circuit just picks up the pulse when the LED (on the front of the Presence Detector module) first lights.</p>
4	<p>Place the hardwire two feet beyond the original location and verify that the LED on the Presence Detector module remains dark.</p> <p>Readjust R24, as necessary.</p>
5	Verify correct track gauge of 56 1/4".
6	<p>Before leaving the location:</p> <ul style="list-style-type: none"> • Remove the hardwire shunt. • Perform an operational test of the system. • Verify the radio is on and tuned to the correct frequency. • Cleanup the location. • Lock the location.

Continued on next page

Quarterly Maintenance, Continued

**Shutter door
linkage
lubrication**

Annually, remove the scanner cover and lubricate the shutter door linkage.

Step	Action
1	Remove the seven screws (six on top and one on bottom of the scanner) that secure the cover to the scanner base and remove the cover.
2	Lubricate scanner shutter door linkage with powdered graphite.
3	Replace the cover and reinstall the seven cover screws.

System Configuration

Chapter Overview

Purpose This section describes the Sentry System 2100-950 with STC Series 2100 scanners. It provides a description of the system and components, and how the system generates alarms.

Scope Topics covered in this chapter include:

- System Description
- Defect Reporting
- History Files
- Operating Environment
- Theory of Operation
- Functional Description

Figure 13-13 Sentry System Electronics Enclosure.



System Overview

System Description

The Model 2100-950 Sentry System is a full-featured detection and reporting system. It monitors moving trains, providing real-time detection of:

- Overheated bearings
 - Overheated wheels, when wheel scanners are installed and enabled
 - Dragging equipment, when dragging-equipment detectors are installed and enabled
 - Shifted loads, when wide-load detectors are installed and enabled
 - Oversized loads, when high-load detectors are installed and enabled
 - Direction of the train
 - Exit speed of the train
-

Defect Reporting

The system monitors trains traveling from 5 to 90 mph (8 to 145 kph). It monitors trains heading in either direction on the track.

Currently, the two ways of reporting defects are:

- Announcements made via the road channel
- Reports, which may be printed to provide detailed defect information

When the Sentry System detects a defect, it informs the crew of the affected train. This is done by a digitized voice transmission over an assigned radio channel.

CSX Configuration

In the CSX configuration, there are real-time messages and post-train messages. When enabled, there are also arrival messages. Arrival messages are announced as the train enters the site. Real-time messages are announced as the train is passing over the site.

When the first defect is detected, “you have a defect” is announced. Post-train messages are announced after the train has left the site and all the recorded train data has been processed by the Sentry System. When no defect is detected, “no defects” is announced.

Continued on next page

System Overview, Continued

History Files

The results of train scans are also stored for later use. With this stored data, the system can create formatted reports. To get them at the site, you need a serial printer or computer. With a modem and computer, you can retrieve them remotely.

Operating Environment

The Sentry System operates well in the harsh environments found along right of ways, functioning over a temperature range of -40°F to +160°F (-40°C to +71°C). It also runs in high vibration situations.

Theory of Operation

Within each scanner is a pyrometer that measures change in the amount of infrared radiation emanating from the point at which it is aimed. As the amount of infrared radiation increases, the output from the scanner increases proportionally.

This increase is expressed as a positive-analog voltage. This voltage is routed through a signal conditioning circuit to the CPU board (in the Communications module) where it is converted to a digital value and compared to an alarm limit. If the input value is greater than the alarm limit, an alarm is generated.

Functional Description

The system is divided into two sets of components. These include:

- Track components
- Bungalow components

A complete description of each track and bungalow component is provided in the following chapters.

Track Components

Component Descriptions

Overview Track components include:

- Scanners
 - Transducers
 - Auxiliary-alarm detectors
-

Scanners STC scanners are the primary input devices of the system. Each has:

- A housing that protects the infrared sensor and associated optics.
- A shutter that prevents the entrance of contaminants during periods of inactivity.
- A heater that removes moisture from the infrared sensor assembly.
- A vibration-resistant connection between the scanner and the system electronics.

STC scanners are made up of covers, modules, and mounts. The external housing consists of the cover and mount. The internal module contains the infrared sensor and associated optics.

The module and cover are tightly integrated and rarely should be taken apart.

Scanner Mounts Scanner mounts attach to the rail in a way that ensures that the scanners are:

- Correctly aimed
- Easily re-aimed, if necessary
- Isolated from as much shock and vibration as possible
- Electrically isolated from the rail

The scanner mounts can be installed on either rail, eliminating the need to maintain left-rail and right-rail models.

Continued on next page

Component Descriptions, Continued

Scanner Output The output of the scanners is expressed as degrees above the temperature of the surrounding environment. The scanners obtain their ambient reference from the bottoms of rail cars as they pass over the scanners. If a scanner doesn't detect a temperature change, its output is zero.

As a bearing passes through the scanner's field of view, the higher level of infrared radiation causes the scanner output to increase proportionally. When the bearing passes out of the field of view, the scanner output returns to zero.

Figure 13-14 STC 2100 Series scanner.



Transducers Transducers are rail-mounted electromagnetic devices that provide the timing signals that allow the Model 2100-950 Sentry System to:

- Detect a train's presence.
- Coordinate gating.
- Determine a train's direction.
- Calculate a train's exit speed.
- Calculate a train's length.
- Identify individual railcars and locomotives based on axle spacing patterns.

Continued on next page

Component Descriptions, Continued

Transducer Operation

Transducers consist of a horseshoe magnet with a tightly wound coil, encapsulated in a rigid epoxy potting compound. Each transducer is mounted between 1-5/8 inches and 1-3/4 inches below the top of the rail.

As the wheels of a railcar pass over the transducer, the wheel flange disturbs the flux field of the magnet, causing the output of a sinusoidal waveform of varying amplitude. The depth of the flange and the speed at which the wheel is moving determines amplitude.

Transducer Types

The Sentry System uses two types of transducers. Both are identical, but are named differently, depending on their location and their function. One type is called a Gating transducer. The other is called Advance transducer. Since CSX isn't currently using Advance transducers, they aren't described here. (CSX uses a track circuit instead of two Advance transducers.)

At each site, CSX uses two rail-mounted Gating transducers per track. On the rail nearest the bungalow, these transducers (labeled TO1 and TO2) are mounted near and to the north or east of the bearing scanner. TO1 is the transducer closest to the scanner. They control scan timing and car recognition.



Figure 13-15 Transducer

Continued on next page

Component Descriptions, Continued

Auxiliary- Alarm Detectors

The standard Model 2100-950 Sentry System can support input from up to four external alarm devices. Any device that provides an open set of relay contacts upon alarm detection can be supported by the system.

The system responds to an open contact by announcing the defect and the axle number nearest the defect. Alarm detection and announcement are in real-time. STC supports dragging equipment, high-load, and wide-load alarms. Other alarm devices require custom speech programming.

STC doesn't manufacture any auxiliary-alarm input devices. However, it does supply each site with a dragging-equipment detector.

Bungalow Components

Overview

Components For CSX's Model 2100-950 Sentry System, bungalow components include:

- Communications module
 - Interface module
 - Presence Detector module
 - Power Supply module
 - Modem module
 - RF transmitter (supplied by CSX)
 - RF transmitter antenna (supplied by CSX and mounted outside the bungalow)
 - Shielded temperature probe (mounted outside the bungalow)
-

Electronics Enclosure

Sentry System modules are mounted in an electronics enclosure. A diagram of the enclosure is shown below.

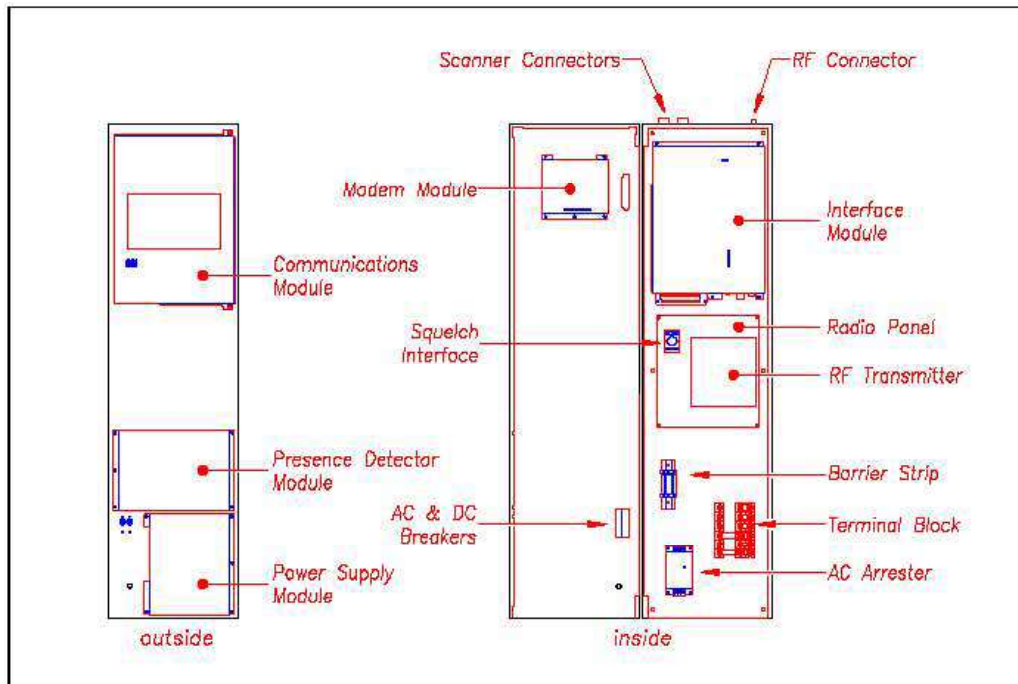

Communications Module

Description The Communications module contains:

- Module cover
- Keypad (on the module cover)
- Liquid-crystal display (LCD) (on the module cover)
- Status LEDs (on the module cover)
- Calibration potentiometers (on the CPU board)
- Communications board
- CPU board
- Talker board

The Communications module acts as the system controller, providing the interface between human and machine that allows all variable system parameters to be set. It controls the train scanning process. It processes the transducer and scanner signals from the track and decides if an alarm condition exists.

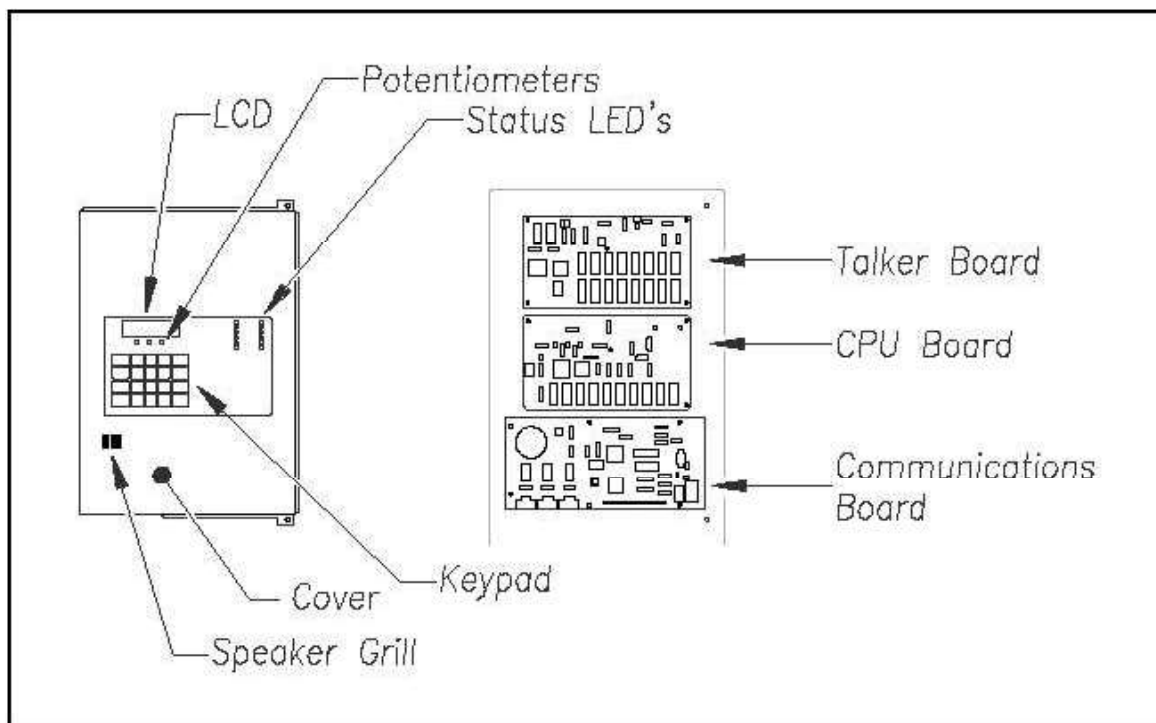

Continued on next page

Communications Module, Continued

Keypad On top of the Communications module is a keypad consisting of 10 digit keys and 10 function keys.

The figure below shows the keypad.

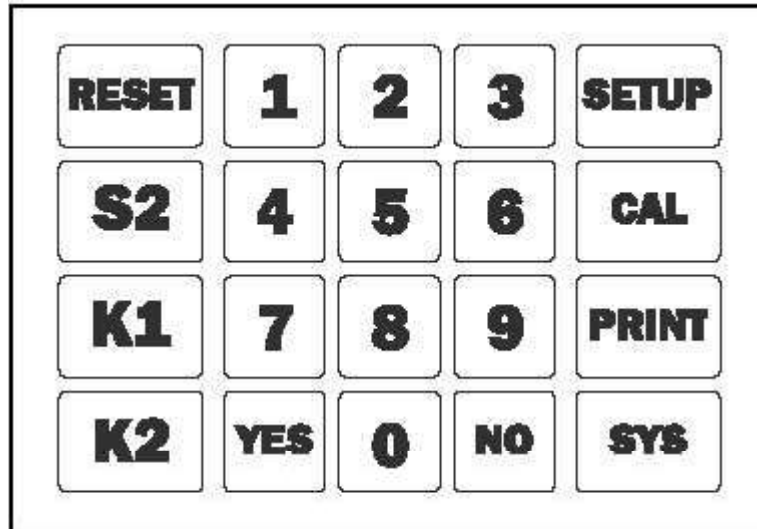

Key	Function
RESET	Resets the CPU and Talker boards.
S2	Holds the shutters on the scanners open while button is pressed.
K1	Not used
K2	When a menu is displayed, returns to the Main screen. When a report is running, stops printing the report.
YES	Selects a menu option for editing and responds to prompts.
NO	Skips a menu option and responds to prompts.
SETUP	Displays the Setup menu.
CAL	Displays the Calibration menu.
PRINT	Displays the Reports menu.
SYS	Displays the System menu.

Continued on next page

Communications Module, Continued

LCD

On top of the Communications module is an LCD consisting of two lines of twenty characters per line. This display shows general information (such as date, time, and ambient temperature), error messages, and results of using the keypad.

Status LEDs

On the module cover are 12 status LEDs. The figure below shows the location of each LED.

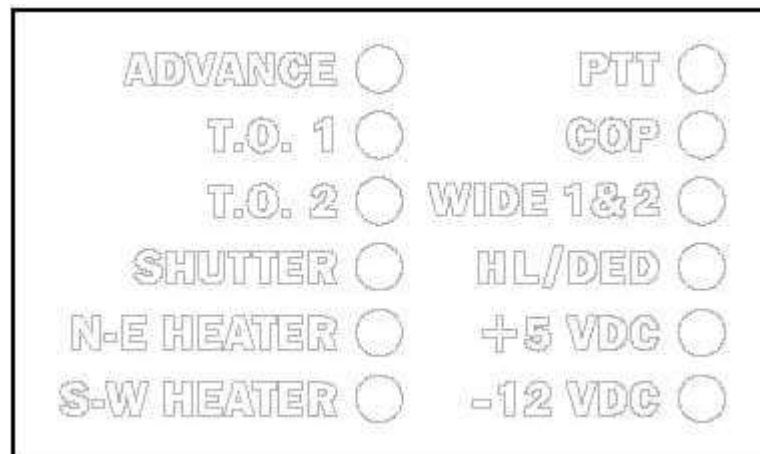

LED	Color	Meaning When Lit
ADVANCE	Yellow	Received pulse from the track circuit
TO1	Yellow	Received pulse from Gating transducer TO1
TO2	Yellow	Received pulse from Gating transducer TO2
SHUTTER	Red	Sent signal to open all shutters. Stays lit as long as the scanner shutters are open.
N-E HEATER	Red	Sent signal to turn on all scanner heaters on the north or east rails. Stays lit as long as these heaters are on.
S-W HEATER	Red	Sent signal to turn on all scanner heaters on the south or west rails. Stays lit as long as these heaters are on.

Continued on next page

Communications Module, Continued

Status LEDs (continued)

LED	Color	Meaning When Lit
PTT	Green	Activate RF transmitter. Stays lit while the transmitter is sending messages.
COP	Red	Computer Operating Properly (COP) - The CPU board or Talker board is malfunctioning. Continues flashing as long as the CPU board or talker board isn't operating properly.
WIDE 1&2	Red	Received open circuit from wide-load detector.
HL/DED	Red	Received open circuit from high-load detector or dragging equipment detector.
+5 VDC	Green	Proper DC voltage is present in the Communications module. Stays lit as long as the Model 2100-950 Sentry System is powered up.
-12 VDC	Green	Proper DC voltage is present in the Communications module. Stays lit as long as the Model 2100-950 Sentry System is powered up.

Communications Board The Communications board is responsible for train data storage, data communications, data polling, reporting, and various other tasks. The CPU board (in the Communications module) sends collected train data to the Communications board for longer term storage. The CPU board itself stores train data only as the train is scanned.

The CPU board and Communications board periodically check communications between each other. When the Communications board is busy, but not locked up, the CPU board displays “Comboard Busy” on the LCD. When the Communications board doesn't respond at all, the CPU board displays “Comboard Error” on the LCD.

Continued on next page

Communications Module, Continued

Communications Board (continued) The CPU board calculates a checksum for each train. This checksum is stored on the Communications board with the train data. If the checksum doesn't match a Communications board calculated checksum, the Train Summary report and Train Detail report note this discrepancy.

In addition, each axle has a checksum associated with it. If an axle is determined to have an invalid checksum, the Train Detail report notes this discrepancy in the associated axle's row.

CPU Board The CPU board:

3. Processes input from scanners, transducers, and auxiliary-alarm detectors.
 4. Compares inputs to predefined alarm criteria and makes alarm decisions.
 - Issues commands to the Talker board.
 - Temporarily stores train data.
 - Sends train data to the Communications board.
 - Maintains system setup parameters.
 - Scans and processes input from the keypad.
 - Displays menus for data input and retrieval.
 - Controls scanner shutter and heater operation.
-

Talker Board The Talker board transmits voice messages to the train crew. It receives various commands from the CPU board during and after train passage. The CPU board decides what needs to be announced and sends high-level commands to the Talker board, which interprets these commands and constructs the appropriate messages.

The Talker board also generates the audio and PTT signals necessary to control the RF transmitter.

Interface Module

Description The Interface module contains:

- Module cover
- Interface board
- Power Indication board
- Distribution board
- Fuse panel
- Module base, which is the electronics enclosure itself

NOTE

Always replace the Interface module cover following any maintenance actions. The cover blocks radio frequency interference from the radio coaxial cable. RF interference can cause transducer miscounts.

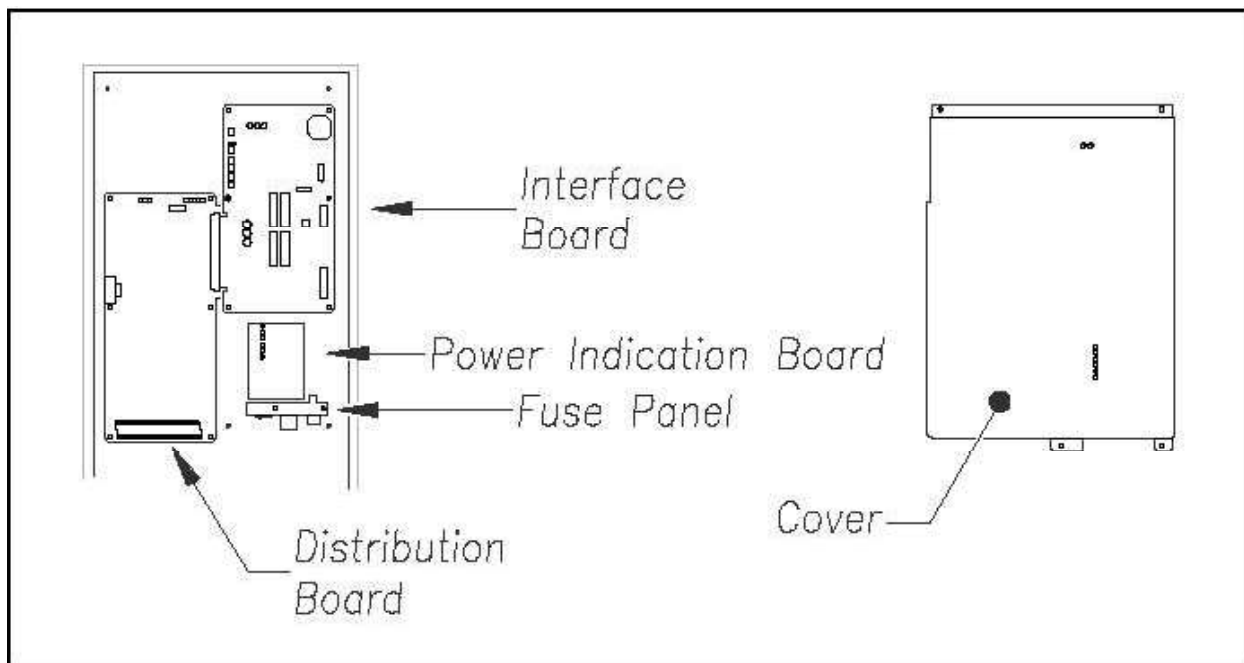

Interface Board The Interface board provides signal conditioning and surge protection for all the inputs from the Distribution board to the Communications module.

Continued on next page

Interface Module, Continued

Power Indication Board

The Power Indication board provides six status lights. They are visible on the front of the Interface module.

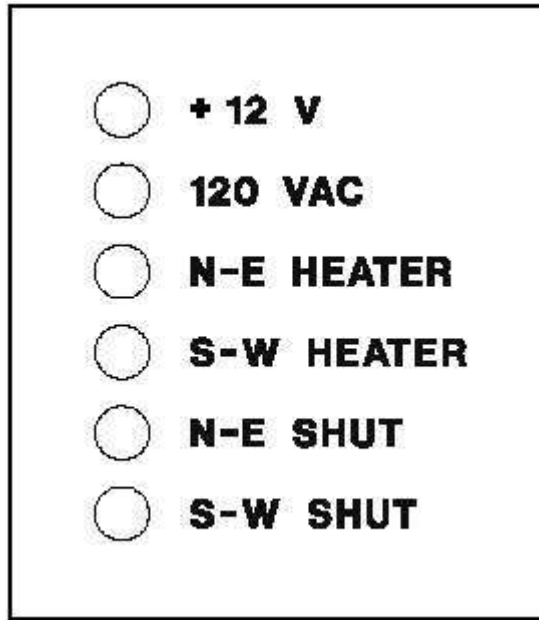

LED	Color	Meaning When Lit
+12 V	Green	Proper DC voltage is present for the entire Model 2100-950 Sentry System. Stays lit as long as the Sentry System is powered up.
120 VAC	Green	Proper AC voltage is present for the entire Model 2100-950 Sentry System. Stays lit as long as the Sentry System is powered up and AC is present.
N-E HEATER	Red	All scanner heaters on the north or east rails are on. Stays lit as long as these heaters are on.
S-W HEATER	Red	All scanner heaters on the south or west rails are on. Stays lit as long as these heaters are on.

Continued on next page

Interface Module, Continued

Power Indication Board (continued)

LED	Color	Meaning When Lit
N-E SHUT	Red	Stays lit as long as power is applied to the shutters.
S-W SHUT	Red	Stays lit as long as power is applied to the shutters.

Distribution Board

The Distribution board provides the input-and-output connections between the Sentry System and the various pieces of external equipment. All equipment is wired via the Faraday cage, to a barrier strip, to a terminal block on this board.

Fuse Panel

The Fuse panel consists of a speaker volume switch, a power-input plug, and two fuses.

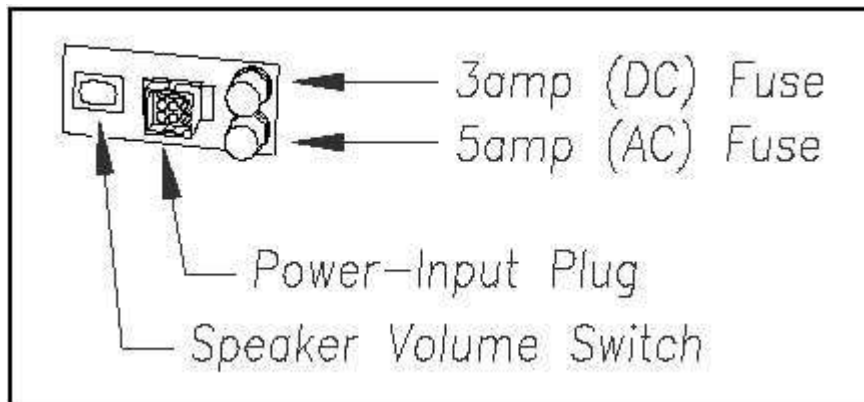

Presence Detector Module

Description The Presence Detector module tells the Model 2100-950 when a train is passing the site.

LED On the front of the module is an LED. When lit, this LED indicates a received pulse from the track circuit. If everything is functioning properly, a lit LED indicates that a train is present.

When unlit, the LED indicates no pulse from the track circuit. If everything is functioning properly, an unlit LED indicates that no train is present.

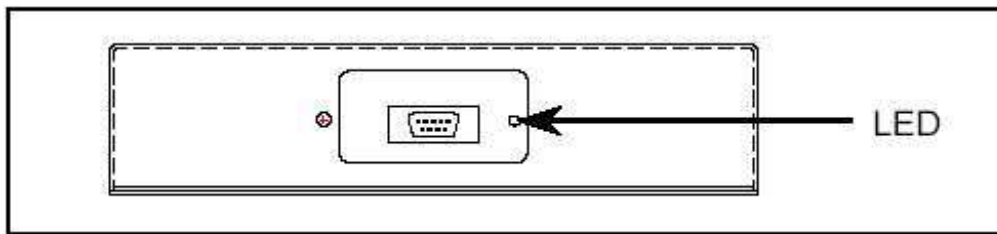

*Figure 13-16
Presence Detector
Module.*

Power Supply Module

Description The Power Supply module contains:

- Module cover
 - Fuses
 - Potentiometers
 - Status LEDs
 - Power converter and battery charger
 - Power Supply board
 - Module base
-

Outputs The Power Supply module is a combination power supply and battery charger for the Sentry System. Three DC outputs are provided:

- 24-volt output capable of charging batteries.
- 12-volt (adjustable) output capable of 4-amps maximum current.
- 5-volt (adjustable) output capable of 5-amps maximum current.

Input power is 104 VAC to 127 VAC. When AC power fails, the 12 VDC and 5 VDC outputs are supplied from the batteries. LED indicators are provided for the three DC outputs, the AC input, and an AC power fail condition. A relay contact closure is also provided for the AC power fail condition.

All connections to the Power Supply module are made through a pluggable terminal block (TB1).

Power Supply Board The Power Supply board provides filtering and regulation of the DC voltages used by the Sentry System. It also provides LED indicators for the input and output voltages and a terminal block for connections to the barrier strip and the Fuse panel.

Fuses are provided on the board for the AC input and 24-volt DC output.

Continued on next page

Power Supply Module, Continued

Status LEDs On the edge of the Power Supply board are five status LEDs.

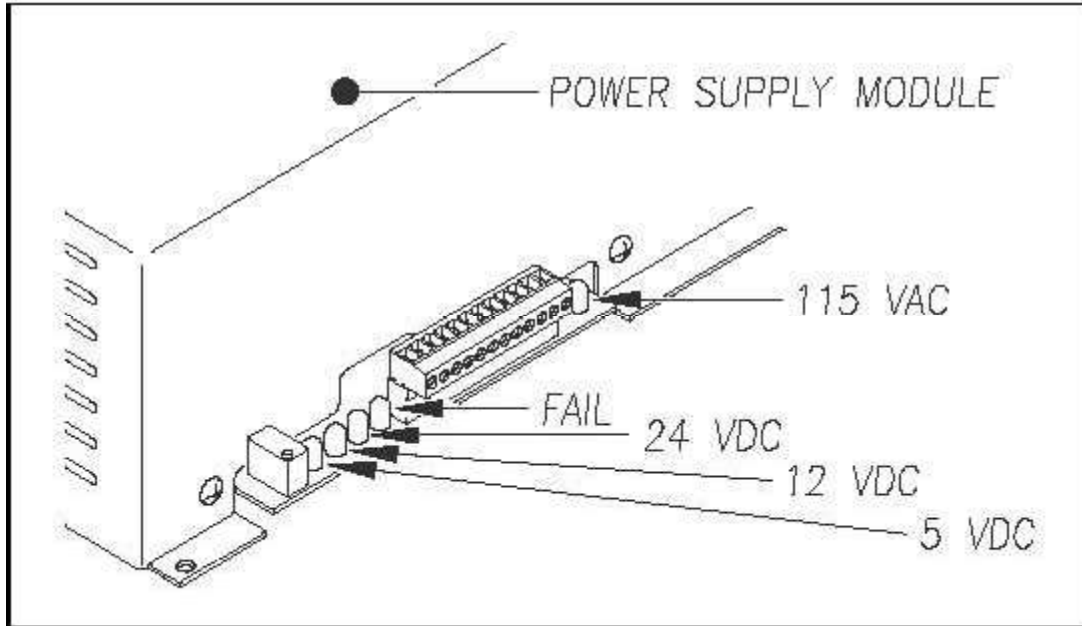

LED	Color	Meaning When Lit
5 VDC	Green	Proper DC voltage is present at terminal 6 on TB1. Stays lit as long as the system is powered up and DC is present.
12 VDC	Green	Proper DC voltage is present at terminal 8 on TB1. Stays lit as long as the system is powered up and DC is present.
24 VDC	Green	Proper DC voltage is present at terminal 4 on TB1. Stays lit as long as the system is powered up and DC is present.
FAIL	Red	Proper AC voltage is not present at terminal 10 on TB1. Stays lit as long as the system is powered up, AC is not present, and the system is running on battery backup..
115 VAC	Green	Proper AC voltage is present at terminal 10 on TB1. Stays lit as long as the system is powered up and AC is present.

Continued on next page

Power Supply Module, Continued

Power Converter and Battery Charger

Inside the module is the power converter and battery charger, consisting of these major parts:

- Transformer
- Bridge rectifier
- Filter capacitors
- Regulators
- DC-DC converter

The Power Supply module converts externally supplied 120 VAC to a regulated 12 VDC and 24 VDC. The regulated 24 VDC is also used to float charge the standby battery system. This allows continued system operation for one to three days (depending upon train movements) when there is an interruption in the externally supplied 120 VAC.

Figure 13-17 Power Supply Module LEDs and AC/DC circuit breakers.



Modem Module

Description The Modem module is a device that lets the system (at the site) communicate with a computer (away from the site) over the telephone lines.

Status LEDs On the module cover are 10 status LEDs.

LED	Meaning When Lit
14	Lights when the modem is set for 14,400 bps operation.
19	Lights when the modem is set for 19,200 bps operation. Both the 19 and 14 LEDs light when the modem falls back to 16,800 bps V.32 turbo mode.
96	Lights when the modem is set for 9,600 bps operation.
CD	Lights when valid carrier signal from another modem is detected.
EC	Lights when the modem is in error-correction mode. Flashes when compression is activated.
FX	Lights when the modem is in fax mode.
OH	Lights when the phone line is off-hook, which occurs when the modem is dialing, on-line, or answering a call. Flashes when the modem is pulse dialing.
RD	Blinks when data is being received.
TD	Blinks when data is being transmitted.
TR	Lights when the modem is ready for an outgoing call or incoming call.



Figure 13-18 Modem Module

Radio Panel

Description The Radio panel is the mounting point for the RF transmitter and squelch interface.

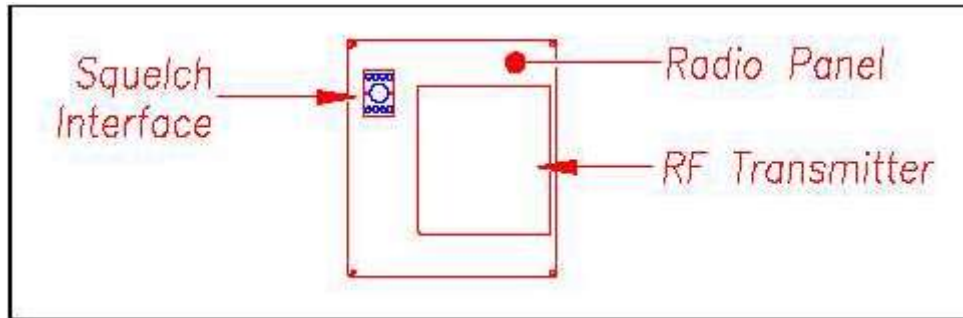

RF Transmitter The RF transmitter and its antenna are supplied and installed by CSX.

The Model 2100-950 Sentry System supports:

- 12 VDC power supply
- Push-to-Talk control
- Adjustable audio level
- Hold-off In (carrier detect)

Squelch Interface The squelch interface (also called the hold-off interface) is an optically coupled device that connects the squelch-detect signal from the RF transmitter to terminal 11 of the Distribution board (in the Interface module).

This device changes the active-high signal that the transmitter sends into the active-low signal that the Sentry System requires. This device is wired at the factory. No additional wiring is needed.

Shielded Temperature Probe

Description

The shielded temperature probe, which mounts to the outside wall of the bungalow, provides accurate temperature indications over a range of -49°F to $+149^{\circ}\text{F}$ (-45°C to $+65^{\circ}\text{C}$). Ambient temperature at the site (at the time the train passed the site) is included with most system reports.



Operation

The Model 2100-950 Sentry System supplies 12 volts to the shielded temperature probe. The probe returns 0 to 5 volts.

Zero volts indicates a -45°C (-49°F) reading. Five volts indicates a $+65^{\circ}\text{C}$ ($+149^{\circ}\text{F}$) reading.

Troubleshooting

Chapter Overview

Purpose This chapter provides guidelines for troubleshooting the Sentry System 2100-950.

Scope This chapter covers the following topics:

- Standard Troubleshooting Procedure
 - Troubleshooting
 - Float Voltage Adjustment
 - Train Movement
-

Standard Troubleshooting Procedure

Introduction

CSXT's Quality Action Council has adopted a standard troubleshooting procedure to ensure a systematic approach to all problems relating to defect detector equipment.

Standard Procedure

The standard troubleshooting procedure is listed below:

Step	Action
1	Identify the trouble symptom. a) Get as much information as possible from the train crew or dispatcher. b) Perform a visual inspection.
2	Sectionalize the problem. a) Use a laptop computer or PDA, if available, to download train data. b) Look at the rail or trackside equipment related to the signal input, such as scanners, transducers, etc...
3	Localize the problem. a) Check input and system voltages. b) Refer to the logbook for previous voltage readings. c) Simulate a test train by performing an operational test as shown on page 13-7.
4	Isolate the problem to locate the faulty circuit by: <ul style="list-style-type: none">• Checking multimeter readings.• Doing a thorough visual inspection.
5	Repair the problem.
6	Perform an operational test. Do not assume that finding one fault repairs the equipment.

Troubleshooting

Problem and Possible Causes

The tables below list problems and possible causes. These tables are a quick reference to assist in troubleshooting. For detailed troubleshooting procedures relating to Sentry System discrepancies, refer to the *Model 2100-950 Sentry System User's Guide for CSX*.

Messages

Refer to the table below for communication-related error messages.

Problem	Possible Cause
Com Board Error displayed on LCD	<ul style="list-style-type: none">• Loss of 24 VDC to Communications board• Defective Communications board• Improper power-up sequence
DRAM Test Failed displayed on LCD	<ul style="list-style-type: none">• Missing or defective DRAM• Defective Communications board

LEDs

Refer to the table below for LED-related discrepancies.

Problem	Possible Cause
Power Supply module 115 VAC LED dark	<ul style="list-style-type: none">• No AC power• Blown AC fuse (on Power Supply board)• Defective AC arrester• Defective Power Supply module
Power Supply module 24 VDC LED dark	<ul style="list-style-type: none">• No AC power for an extended period• Improperly adjusted float voltage• One or two defective batteries• Blown DC fuse (on Power Supply board)• Defective Power Supply board
Interface module 120 VAC LED dark	<ul style="list-style-type: none">• No AC power• Blown AC fuse (on Fuse panel)• Improperly connected plug (on Fuse panel)
Interface module +12 V LED dark	<ul style="list-style-type: none">• No 12 VDC supply• Defective wiring or connections• Defective Power Supply module

Continued on next page

Troubleshooting, Continued

LEDs (continued)

Problem	Possible Cause
Communications module +5 VDC LED dark	<ul style="list-style-type: none">• No 12 VDC supply• Defective CPU board• Defective Talker board
Communications module -12 VDC LED dark	<ul style="list-style-type: none">• No 12 VDC supply• Defective CPU board• Defective Talker board
Communications module COP LED flashing	<ul style="list-style-type: none">• Defective CPU board• Defective Talker board

Integrity Failures Refer to the table below for system integrity alarms. To view integrity failures, a laptop computer or PDA must be connected to the Sentry unit. Laptop connection procedures are found in the Computer Interface chapter.

Alarm	Possible Cause
Cold Rail	<ul style="list-style-type: none">• Improper calibration or alignment• Dirty optics• Stuck shutter• Blocked scan path• Defective scanner
Successive Cold Rails Exceeded	<ul style="list-style-type: none">• Location of trackside hardware• Location of site• Improper calibration or alignment• Dirty optics• Stuck shutter• Blocked scan path• Defective scanner

Continued on next page

Troubleshooting, Continued

Integrity Failures (continued)

Alarm	Possible Cause
Cold Resistor	<ul style="list-style-type: none"> • Improper calibration • Dirty optics • Stuck shutter • Inoperative shutter resistor • Defective scanner
Successive Cold Resistors Exceeded	<ul style="list-style-type: none"> • Improper calibration • Dirty optics • Stuck shutter • Inoperative shutter resistor • Defective scanner
Dead Resistor	<ul style="list-style-type: none"> • Stuck shutter • Improper calibration • Defective scanner
Low Battery or Dead Battery	<ul style="list-style-type: none"> • No AC power for an extended period • Defective wiring or connections • Improperly adjusted float voltage • One or two defective batteries
Midrange Transducer Miscounts or Highrange Transducer Miscounts	<ul style="list-style-type: none"> • Slow train movement • Improper loading of transducers • Transducer connections intermittent • Transducers not adjusted correctly on rail • Defective transducer
Stuck Dragger Pretrain or Stuck Dragger During Train Passage	<ul style="list-style-type: none"> • Malfunctioning dragging-equipment detector • Malfunctioning cables or wires • Improperly installed dragging-equipment detector • Improperly connected cables or wires • Defective components on Interface board • Defective components on CPU board • Missing jumper wire, when dragger isn't installed

Continued on next page

Troubleshooting, Continued

Integrity Failures (continued)

Alarm	Possible Cause
Stuck High/Wide Load Detector Pretrain	<ul style="list-style-type: none"> • Malfunctioning high/wide load detector • Malfunctioning cables or wires • Improperly installed high/wide load detector • Improperly connected cables or wires • Defective components on Interface board • Defective components on CPU board • Missing jumper wire, when detector isn't installed

Other Problems Refer to the table below for miscellaneous other problems that may be encountered.

Problem	Possible Cause
Stuck High/Wide Load Detector Pretrain alarm	<ul style="list-style-type: none"> • Malfunctioning high/wide load detector • Malfunctioning cables or wires • Improperly installed high/wide load detector • Improperly connected cables or wires • Defective components on Interface board • Defective components on CPU board • Missing jumper wire, when detector isn't installed
Spiking (one rail)	<ul style="list-style-type: none"> • Defective scanner • Loose connections • A track pumping or running more than two inches
Spiking (both rails)	<ul style="list-style-type: none"> • Defective CPU board • Defective Interface board • A track pumping or running more than two inches
Transducer miscounts	<ul style="list-style-type: none"> • Interface module cover not installed

Continued on next page

Troubleshooting, Continued

Other Problems (continued)

Problem	Possible Cause
Shutters don't open	<ul style="list-style-type: none"> • Blown DC fuse (on Fuse panel) • Loose connection • Shutter relay inoperative • Defective shutter solenoid
Low heat on one rail	<ul style="list-style-type: none"> • Improper calibration • Defective heater control relay • Defective scanner heater • Improper scanner alignment • Obstructed lens
Low heat on both rails	<ul style="list-style-type: none"> • AC power off • Snow heaters inoperative • Improper scanner alignment • Obstructed lens • Defective Interface board
No measurable heat on one rail	<ul style="list-style-type: none"> • Defective shutter motor • Loose connections • Defective shutter relay • Blocked scanner • Defective scanner
No measurable heat on both rails	<ul style="list-style-type: none"> • Blown DC fuse (on Fuse panel) • Inoperative 12 VDC power supply • Defective shutter relay • Defective CPU board
No voice response	<ul style="list-style-type: none"> • Defective antenna connection • Inoperative RF transmitter • Inoperative Talker board • Improperly adjusted transmit audio • Sentry System not running
Incorrect reading from Shielded Temperature Probe	<ul style="list-style-type: none"> • Malfunctioning temperature probe • Cut cable or cut wire within cable • Disconnected wiring

Continued on next page

Troubleshooting, Continued

Transducer Problems

To check the transducer, follow these steps.

Step	Action
1	Connect a voltmeter across the transducer terminals in the junction box and/or arrestor panel.
2	Attach the positive lead to the black wire and the negative lead to the white wire.
3	Set the voltmeter on the low DC voltage scale.
4	Insert a metal object in the transducer's magnetic field. <u>Result:</u> Insertion of the metal object should result in a positive meter movement. (Retraction of the object should result in a negative deflection.)
5	If no meter movement is indicated in the above test, check for an open transducer coil using an ohm meter. The transducer should read approximately 150 ohms +/- 10%.

Float Voltage Adjustment

Overview Potentiometer R9 on the Power Supply board is used to adjust float voltage. At the factory, it is adjusted for a value of 28 VDC. When the voltage is not between 27.8 and 28.2 VDC, you should adjust R9 until the multimeter shows 28 VDC.

Procedure Follow the steps below to check and adjust float voltage.

Step	Action
1	Verify the 115 VAC and 24 VDC LEDs on the edge of the Power Supply are illuminated.

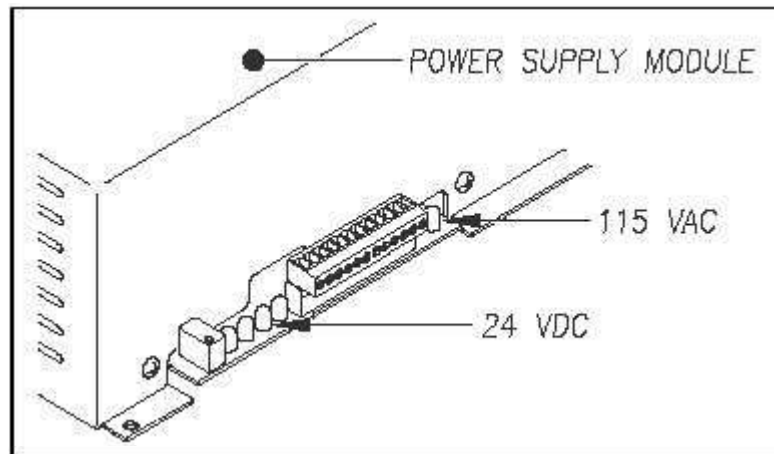

2	Toggle the DC breaker on the inside cover of the Electronics Enclosure to the OFF position.
---	---

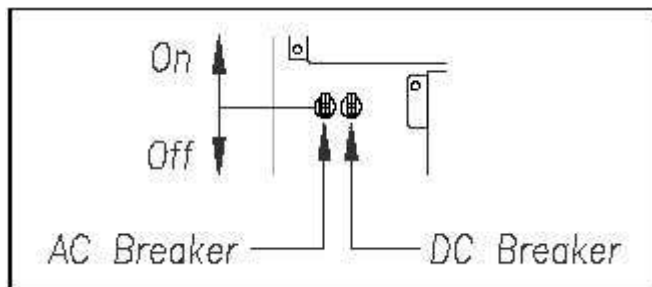

Continued on next page

Float Voltage Adjustment, Continued

Procedure (continued)

Step	Action
3	On a multimeter, switch to the DC volts scale. Then: <ul style="list-style-type: none">• Touch the black lead of the multimeter to terminal 3.• Touch the red lead of the multimeter to terminal 4.

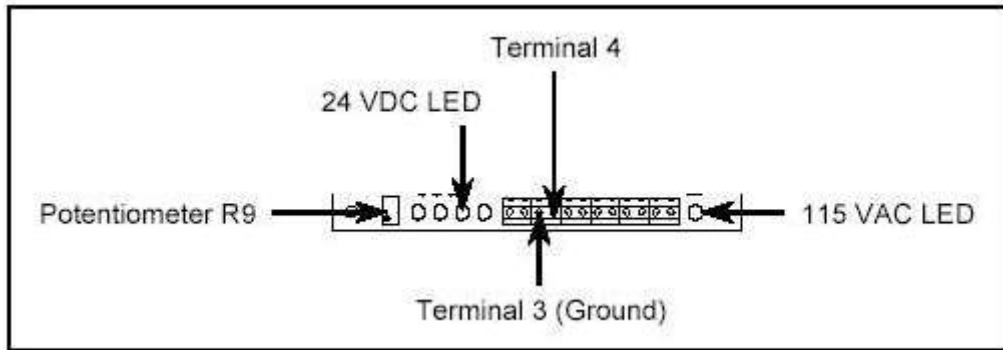

4	If the voltage is not between 27.8 and 28.2 VDC, adjust potentiometer R9 until the multimeter reads 28 VDC.
5	Toggle the DC breaker on the inside cover of the Electronics Enclosure to the ON position.

Train Movement

Process

The following illustrates how the 2100-950 Sentry System processes a train during these three stages as a train:

5. Approaches.
6. Occupies the site.
7. Moves offsite.



<i>Train Approach</i>	<i>Train On-site</i>	<i>Train Offsite</i>
1. Track circuit activates, COMM module ADVANCE LED on, Presence Detector module LED on.	1. System sets direction with first good pulse from TO1 or TO2.	1. Track circuit drops at 100 feet, ADVANCE LED and Presence Detector LED extinguish.
2. System: <ul style="list-style-type: none"> • Opens shutters. • Turns heaters off. 	2. System: <ul style="list-style-type: none"> • Processes heat data for every axle. • Stores data and alarms • Announces real-time alarm messages. 	2. System: <ul style="list-style-type: none"> • Closes shutters. • Turns heaters on.
3. System checks for auxiliary alarm detectors stuck in the active (alarming) state.	3. As long as the track circuit is activated, system continues to collect and analyze heat data. Remainder of the train will be processed if the train stops at location.	3. System: <ul style="list-style-type: none"> • Calculates departure speed based on last eight axles. • Performs post-train self-test.
4. System flags track circuit failure (if it occurs) as non-fatal and continues processing train.		4. End of Train message transmitted.

Continued on next page

Train Movement, Continued

Arrival Message

The Arrival Message option is set according to local policy. To enable/disable the message, go to the Messages submenu of the Sentry System Setup menu.

Real-Time Messages

Real-time messages consist of announcements that occur as the train is passing over the site. No matter what kind of defect is detected, there is only one format for this announcement.

The format for this message is shown below:

“CSX Detector, Milepost 3-9-9 Point 4, You have a defect.”

No matter how many defects are found, the real-time message is only announced once.

Post-Train Messages

Post-train (end-of-train) announcements are given after the train has left the site and all recorded train data has been processed by the Sentry System. Refer to the *Model 2100-950 Sentry System User's Guide for CSX* for a detailed explanation of messages and message format.

Computer Interface

Chapter Overview

Purpose This chapter describes the types of information available through a computer interface with the Sentry System.

Scope Topics covered in this chapter include the following reports that are available through a computer interface with the defect detector unit:

- Train Summary
 - Train Detail
 - Exception Summary
 - Exception Detail
 - Abbreviated Exception Detail
 - System Status
 - Last Train
 - Last Ramp Train
 - Event Log
-

Main Menu

Communication Connection Refer to Section 1A of this manual for the procedure to make a laptop computer connection with the Sentry System.

Connect the laptop to the COM3 port on the Sentry System Communication module.

NOTE

The Emulation setting in HyperTerminal must be set to **ANSI** in order for the computer to communicate with the Sentry System. Refer to the topic **Changing the Communication Settings** in Section 1A of this manual.

Accessing the Main Menu Once a HyperTerminal connection has been established with the defect detector, press the **Esc** key on the laptop computer to view the Sentry System Main Menu. A sample Main Menu screen is shown below.

```
STC Sentry System, Milepost-1794.5Z, Track:Single
05/26/02 12:48
Main Menu
-----
A) Train Summary
B) Train Detail
C) Exception Summary
D) Exception Detail
E) System Status
F) Last Train
G) Last Ramp Train
H) Event Log
I) Replay EOT Announcement
J) Setup Menu
K) Enter Pass-Thru Mode
L) DRAM Test Results
X) End
?
```

Options Numerous options are available from the Main Menu, including access to reports and logs that are useful in determining the status of defect detector. To access an option, simply type the letter corresponding to the desired option.

Continued on next page

Main Menu, Continued

Exiting the Main Menu

To exit the Main Menu and return the Sentry System to normal operation, type **X** on the laptop computer.

Train Summary Report

Overview The Train Summary report lists all trains currently stored in the Trains directory. A train number is shown for each train entry so that a Train Detail report can easily be produced for any train listed on the summary.

Accessing the Train Summary To access the Train Summary report, type **A** at the Main Menu of the Sentry System. A sample Train Summary report is shown below. Review the Train Summary for errors, integrity alarms, and any other unusual occurrences.

```

Southern Technologies Corporation
Sentry System Detector
TRAIN SUMMARY
-----
Version Info.... Analyzer: 1.01a 01/10/02           Milepost: 1234.5
                  Talker: 2.02b 02/20/02           Track: Single
                  Communicator: 3.03c 03/30/02
Alarm Limits...  Absolute: 150           Carside Slope.... 1.31
                  Differential: 90         Minimum... 100
                                      Cold Rail Temp... 20
-----
Train#  Date   Time  Cars Axles T01 T02  Speed  Dir  Rail  Amb  Rat
              Average
              North South  Temp
-----
178    06/22/02 15:47  18   78   78  78   53   W   56   21   77   28.1v
177 A  06/21/02 08:32  20   86   86  86   56   E   36   37   68   28.2v
176 I  06/21/02 07:40  10   46   46  46   57   E   43    7   66   28.2v
175 B  06/21/02 06:28  14   62   62  62   57   E   36   37   60   28.2v
174    06/20/02 11:33  18   78   78  78   53   W   55   55   73   28.1v
173    CHECKSUM ERROR: StartAddr 134879 EndAddr 134930
172    06/20/02 01:19  18   78   78  78   55   E   58   20   59   27.7v
171    06/19/02 11:24  53  218  218  218   49   E   54   18   72   28.1v
170 I  06/19/02 01:22   8   38   38  38   53   E   55   18   60   28.1v
          .
          .
          .

```

Continued on next page

Train Summary Report, Continued

Report Layout The report is divided into a header section and a detail section. The header section contains general information about the site and the detail section contains summary information on each train that has passed the site.

NOTE

Information scrolls from the bottom of the screen to the top of the screen.

To stop the scrolling and examine a specific set of information, press the spacebar on the laptop computer. To resume scrolling, press the spacebar again.

Information Fields The table below describes the fields of information displayed in a Train Summary report.

Heading	Contents of Field
Version Info	Software version number and release date for the following system components: <ul style="list-style-type: none">• Analyzer• Talker• Communicator
Milepost	The site's five-digit milepost with a suffix, if any.
Track	The site's track designation. Valid designations are: <ul style="list-style-type: none">• Single• North, south, east, or west• Main 1, 2, or 3
Alarm Limits	The alarm parameters currently defined in the system setup.
Train #	The number that identifies the train in the Trains directory.
(failure code)	Space between the train number and date where failure codes are displayed. One of three codes will be displayed when the system detects a defect or internal failure: A = Exception Alarm (detected defect) I = Integrity Failure (internal failure) B = Both an Exception Alarm and an Integrity Failure were detected.
Date	The date the train passed the site.
Time	The time the train passed the site.

Continued on next page

Train Summary Report, Continued

Information Fields (continued)

Heading	Contents of Field
Cars	The total number of cars counted by the Model 2100-950.
Axles	The total number of axles counted by the unit.
TO1	The total number of hits counted by transducer TO1.
TO2	The total number of hits counted by transducer TO2.
Speed (mph)	Exit speed of the train in miles-per-hour.
Dir	Direction the train was traveling (N, S, E, or W).
Rail Average	Average temperature read by bearing scanners on the north and south, or east and west rails.
Amb Temp	Ambient temperature when the train passed the site.
Bat	Backup battery voltage at the time the train passed the site.

Train Detail Report

Overview The Train Detail report provides detailed information on a single train. When choosing this report, you will be prompted to enter a train number from the Train Summary report.

Accessing the Train Detail To access the Train Detail report, type **B** at the Main Menu of the Sentry System, type the train number, then press **Enter**. A sample Train Detail report is shown below.

```

Southern Technologies Corporation
Next Generation Detector System
TRAIN DETAIL
-----
Train#: 64           Speed: 23MPH           MP/KP: 0911.2
Date: 01/15/07      Axles: 4             Track: Single
Time: 21:08         Direction: South     Temperature: + 65F
Length: 50          Shutters Open: 17   Battery: 13.7v
-----
Filters
-----
Resistor
Rail Max Avg Read Req Txdr Counts Alarm Limit Carside Parms
-----
East 9 10 70 OT T01 4 Absolute 150 Slope: 1.31
West 9 10 107 OT T02 4 Differential 90 Minimum: 90
Hot Wheel 500
Resistor Test Mode: Reduced Cold Rail Temp 10
-----
Firmware Versions
-----
Analyzer: CSXA1.03-A 07/19/06 Comm: CSXA1.04-A 07/19/06
-----
System Alarms
-----
Cold East Rail
Cold West Rail
VERY Slow Train
Short Train
No Approach Track
Axle Alarm Summary
2 Dragging Equipment
-----
Car Axle Trk East West ON OFF PW1 PW2 Alarms
1 1 0 17 14 249 0 41 38
2 1 9 11 288 2274 53 50 Dragging Equipment
2 3 2 9 9 293 1630 45 41
4 2 9 9 291 1613 48 45

```

Continued on next page

Train Detail Report, Continued

Report Layout The report is divided into a header section and a detail section. The header section contains general information about the site at the time the train passed. The detail section contains detailed information on a specific train.

NOTE

Information scrolls from the bottom of the screen to the top of the screen. To stop the scrolling and examine a specific set of information, press the spacebar on the laptop computer. To resume scrolling, press the spacebar again.

Information Fields The table below describes the fields of information displayed in a Train Detail report.

Heading	Contents of Field
Train #	The number that identifies the train in the Trains directory.
Date	The date the train passed the site.
Time	The time the train passed the site.
Speed	Exit speed of the train in miles-per-hour.
Axles	The total number of axles counted by the unit.
Direction	Direction the train was traveling (North, South, East, or West).
Milepost	The site's five-digit milepost with a suffix, if any.
Track	The site's track designation. Valid designations are: <ul style="list-style-type: none">• Single• North, south, east, or west• Main 1, 2, or 3
Temperature	Ambient temperature (in Fahrenheit) when the train passed the site.
Battery	Backup battery voltage at the time the train passed the site.
Rail	The rail designators for each side of the train (north and south, or east and west).
Max	The maximum temperature (above ambient) for a given rail side.
Avg	The average temperature (above ambient) for a given rail side.

Continued on next page

Train Detail Report, Continued

Information Fields (continued)

Heading	Contents of Field
Resistor	The scanner resistor temperature (read after train passage) for a given rail side.
Txdr Counts	The Gating transducer designator (TO1 or TO2) followed by the total number of hits on that transducer.
Alarm Limit	The Hotwheel alarm level and the Hotbox alarm levels for: <ul style="list-style-type: none"> • Absolute • Differential • Cold Rail Temperature • Pyrometer Saturation Ratio
Carside Parm	Carside Slope alarm parameters. These values were in place at the time the train passed the site.
Firmware Versions	Software version number and release date for the following system components: <ul style="list-style-type: none"> • Analyzer • Talker • Communicator
Integrity Failures	Lists any Integrity Failures detected at the time the train passed the site. See the Troubleshooting portion of this section for a list of Integrity Failures.
Axle Alarm Summary	Lists each Exception Alarm found on the train and the axle on which it was found.
Car	The car number as determined by STC's Car Recognition Algorithm.
Axle	The axle number.
North or East	The bearing scanner temperature recorded for that rail side.
South or West	The bearing scanner temperature recorded for that rail side.
Wheel	If hotwheel is enabled, the recorded wheel scanner temperature. If hotwheel is disabled, this heading does not appear.
ON	The number of milliseconds a bearing was scanned.

Continued on next page

Train Detail Report, Continued

Information Fields (continued)

Heading	Contents of Field
OFF	The number of milliseconds between axles (when no axle was between the transducers).
Alarms	Any Exception Alarm found on the given axle.

Exception Summary Report

Overview The Exception Summary report lists all trains contained in the Exceptions directory. A train is stored in the Exceptions directory if an Exception Alarm or Integrity Failure, or both, was detected as the train passed the site.

Accessing the Exception Summary To access the Exception Summary report, type **C** at the Main Menu of the Sentry System, type the train number, then press **Enter**. A sample Exception Summary report, with the Hotwheel alarm selection disabled, is shown below.

```
Southern Technologies Corporation
Sentry System Detector
EXCEPTIONS SUMMARY
-----
Version Info... Analyzer: 1.01 01/10/02           Milepost: 1234.5
                  Talker: 2.02 02/20/02           Track: Single
                  Communicator: 3.03 03/30/02
Alarm Limits... Absolute: 150           Carside Slope.... 1.31
                  Differential: 90           Minimum... 100
                  Cold Rail Temp... 20
-----
Train#  Date   Time  Cars Axles T01 T02  Speed  Dir  Rail  Avg  Amb  Bat
              Average North South  Temp
-----
177 A 06/21/02 08:32  20  86  86  86  56  E   36  37  68  27.2V
176 I 06/21/02 07:40  10  46  46  46  57  E   43  7  66  27.2V
175 B 06/21/02 06:28  14  62  62  62  57  E   36  37  60  27.2V
171 I 06/19/02 01:22  8  38  38  38  53  E   55  18  60  27.1V
      .
      .
      .
```

Report Layout The report is divided into a header section and a detail section. The header section contains general information about the site. The detail section contains summary information for each exception train.

NOTE

Information scrolls from the bottom of the screen to the top of the screen.

To stop the scrolling and examine a specific set of information, press the spacebar on the laptop computer. To resume scrolling, press the spacebar again.

Continued on next page

Exception Summary Report, Continued

Information Fields

The table below describes the fields of information displayed in a Exception Summary report.

Heading	Contents of Field
Version Info	Software version number and release date for the following system components: <ul style="list-style-type: none"> • Analyzer • Talker • Communicator
Milepost	The site's five-digit milepost with a suffix, if any.
Track	The site's track designation. Valid designations are: <ul style="list-style-type: none"> • Single • North, south, east, or west • Main 1, 2, or 3
Alarm Limits	The alarm parameters currently defined in the system setup.
Train #	The number that identifies the train in the Trains directory.
(failure code)	Space between the train number and date where failure codes are displayed. One of three codes will be displayed when the system detects a defect or internal failure: A = Exception Alarm (detected defect) I = Integrity Failure (internal failure) B = Both an Exception Alarm and an Integrity Failure were detected.
Date	The date the train passed the site.
Time	The time the train passed the site.
Cars	The total number of cars counted by the Model 2100-950.
Axles	The total number of axles counted by the unit.
TO1	The total number of hits counted by transducer TO1.
TO2	The total number of hits counted by transducer TO2.
Speed (mph)	Exit speed of the train in miles-per-hour.
Dir	Direction the train was traveling (N, S, E, or W).
Rail Average	Average temperature read by bearing scanners on the north and south, or east and west rails.
Amb Temp	Ambient temperature when the train passed the site.
Bat	Backup battery voltage at the time the train passed the site.

Exception Detail Report

Overview The Exception Detail report provides detailed information on a single train. When choosing this report, you will be prompted to enter a train number from the Train Summary or Exception Summary report.

Accessing the Exception Detail To access the Exception Detail report, type **D** at the Main Menu of the Sentry System, type the train number, then press **Enter**.

Abbreviated Exception Detail Once you have typed the train number and pressed **Enter**, a prompt will ask you whether you want an Abbreviated Exception report. Type **Y** or **N**, as appropriate.

A standard Exception Report lists every axle in train, whether a defect was detected or not.

The Abbreviated Exception Detail report only displays axle data for:

- The car immediately preceding a car with an alarmed axle
 - The car containing the alarmed axle
 - The car immediately following the car with the alarmed axle
-

Report Layout The report is divided into a header section and a detail section. The header section contains general information about the site at the time the train passed. The detail section contains detailed information on a specific exception train.

NOTE

Information scrolls from the bottom of the screen to the top of the screen. To stop the scrolling and examine a specific set of information, press the spacebar on the laptop computer. To resume scrolling, press the spacebar again.

A sample Exception Detail report is shown on the following page.

Continued on next page

Exception Detail Report, Continued

```

Southern Technologies Corporation
Sentry System Detector
EXCEPTION DETAIL
-----
Train#: 7           Speed: 43           Milepost: 1234.5Y
Date: 02/08/03     Axles: 194        Track: Single
Time: 12:39        Direction: East    Temperature: 51
                                      Battery: 27.2v
-----
Rail Max Avg Resistor Txdr Counts Alarm Limit Carside Params
-----
North 186 77 2 T01 194 Absolute 130 Slope: 1.32
South 181 68 2 T02 194 Differential 90 Minimum: 100
Hot Wheel 556
Cold Rail Temp 17
-----
Firmware Versions
-----
Analyzer: 1.01 01/10/02 Talker: 2.02 02/20/02 Comm: 3.03 03/30/02
-----
System Alarms
-----
Cold North Resistor
Cold South Resistor
Axle Alarm Summary
-----
46 South Rail Absolute
77 South Rail Differential
193 North Rail Absolute
193 South Rail Absolute
194 North Rail Absolute
-----
Car Axle North South ON OFF Alarms
-----
1 1 56 21 25 0
  2 57 21 25 59
  3 56 21 25 59
  4 56 21 25 362
  5 56 21 25 59
  6 56 21 25 59
2 7 56 20 25 162
  8 56 21 25 59
  .
  .
  .
193 186 181 25 59 North Rail Absolute
194 183 170 25 641 South Rail Absolute
North Rail Absolute

```

Information Fields

The table below describes the fields of information displayed in an Exception Detail report.

Heading	Contents of Field
Train #	The number that identifies the train in the Trains directory.
Date	The date the train passed the site.
Time	The time the train passed the site.
Speed	Exit speed of the train in miles-per-hour.

Continued on next page

Exception Detail Report, Continued

Information Fields (continued)

Heading	Contents of Field
Axles	The total number of axles counted by the unit.
Direction	Direction the train was traveling (North, South, East, or West).
Milepost	The site's five-digit milepost with a suffix, if any.
Track	The site's track designation. Valid designations are: <ul style="list-style-type: none"> • Single • North, south, east, or west • Main 1, 2, or 3
Temperature	Ambient temperature (in Fahrenheit) when the train passed the site.
Battery	Backup battery voltage at the time the train passed the site.
Rail	The rail designators for each side of the train (north and south, or east and west).
Max	The maximum temperature (above ambient) for a given rail side.
Avg	The average temperature (above ambient) for a given rail side.
Resistor	The scanner resistor temperature (read after train passage) for a given rail side.
Txdr Counts	The Gating transducer designator (TO1 or TO2) followed by the total number of hits on that transducer.
Alarm Limit	The Hotwheel alarm level and the Hotbox alarm levels for: <ul style="list-style-type: none"> • Absolute • Differential • Cold Rail Temperature • Pyrometer Saturation Ratio
Carside Parns	Carside Slope alarm parameters. These values were in place at the time the train passed the site.

Continued on next page

Exception Detail Report, Continued

Information Fields (continued)

Heading	Contents of Field
Firmware Versions	Software version number and release date for the following system components: <ul style="list-style-type: none">• Analyzer• Talker• Communicator
Integrity Failures	Lists any Integrity Failures detected at the time the train passed the site. See the Troubleshooting portion of this section for a list of Integrity Failures.
Axle Alarm Summary	Lists each Exception Alarm found on the train and the axle on which it was found.
Car	The car number as determined by STC's Car Recognition Algorithm.
Axle	The axle number.
North or East	The bearing scanner temperature recorded for that rail side.
South or West	The bearing scanner temperature recorded for that rail side.
Wheel	If hotwheel is enabled, the recorded wheel scanner temperature. If hotwheel is disabled, this heading does not appear.
ON	The number of milliseconds a bearing was scanned.
OFF	The number of milliseconds between axles (when no axle was between the transducers).
Alarms	Any Exception Alarm found on the given axle.

Appendix

**Table of
Contents**

This section contains the following information.

Appendix A	System Alarm Definitions
Appendix B	Integrity Failure Definitions

System Alarm Definitions

Overview This appendix describes the conditions and events that the Model 2100-950 Sentry System flags as System Alarms. These alarms provide data about passing trains and system status. These alarms are listed under the System Alarms section of the Train Detail and Exception Detail reports.

Alarm	Definition
Integrity Failure Alarm	<p>The Integrity Failure alarm indicates that the SmartScanNG system determined that a condition exists that could prevent proper scanning of a train. In other words, this alarm indicates the existence of one or more conditions in which the integrity of the system, and its ability accurately to record train data, may be compromised. These conditions, called Integrity Failures, are covered in the next appendix</p>
Cold Rail Alarm	<p>The Cold Rail alarm indicates that the temperatures of all bearings (of the train) on the designated rail were below a given temperature. When no bearing on a given rail generates a delta temperature reading greater than or equal to the temperature set by the Cold Rail Temperature option (of the Alarm Limits submenu), the system generates a Cold Rail alarm.</p> <p>There is a different Cold Rail alarm for each rail. That is, there is a Cold North Rail alarm and a Cold South Rail alarm (or, depending on track direction, a Cold East Rail alarm and a Cold West Rail alarm).</p> <p>The maximum number (per rai-side) of consecutive trains, having Cold Rail alarms, allowed before generating a Successive Cold Rails Exceeded alarm is set by the Cold Rail option (of the Alarm Limits submenu of the Setup menu). If the number of consecutive trains bearing identical Cold Rail alarms equals or exceeds the cold-rail-alarm limit, the System Alarms section of the Train Detail and Exception Detail reports displays the message “Successive Cold Rails Exceeded.” A Successive Cold Rails Exceeded alarm is considered a System Alarm if the Announce Cold Rail option (of the Messages submenu) is set to NO. However, it is considered an Integrity Failure if the Announce Cold Rail option was set to YES.</p>

Continued on next page

System Alarm Definitions, Continued

Alarm	Definition
Cold Resistor Alarm	<p>A resistor is mounted to the inside of the bearing scanner's shutter. A voltage is applied to this resistor while the shutter is open, causing it to heat up. After a train has left a site and the shutters have closed, the temperature of the resistor is read by the scanner pyrometer. In this way, a check of the system's ability to correctly read heat is made. The Cold Resistor alarm indicates that the minimum value expected for the temperature of the resistor wasn't met. This minimum value is determined by the firmware and is dependent upon the time it takes a train to pass a site.</p> <p>If the minimum value wasn't met, a second check compares the recorded resistor temperature against the limit that was established using the Absolute option (of the Alarm Limits submenu of the Setup menu). (This alarm limit is an offset, in degrees Fahrenheit, above the ambient temperature.) If the recorded resistor temperature meets or exceeds the absolute-alarm limit, the firmware cancels any previously flagged Cold Resistor alarms.</p> <p>There is a different Cold Resistor alarm for each rail. That is, there is a Cold North Resistor alarm and a Cold South Resistor alarm (or, depending on track direction, a Cold East Resistor alarm and a Cold West Resistor alarm).</p>
Very Slow Train Alarm	The Very Slow Train alarm indicates that, at some point during train passage, four consecutive axles crossed the Gating transducers at a speed of 7 mph (11.3 kph) or less. When this alarm occurs, the system won't announce axle count, exit speed, length of train, and total number of cars (even if these messages are enabled).
Short Train Alarm	The Short Train alarm indicates that a train had fewer than 50 axles.
Low Battery Alarm	The Low Battery alarm indicates a float voltage of at least 18 volts, but less than 22 volts, on the standby batteries.
Midrange Transducer Miscounts Alarm	The Midrange Transducer Miscounts alarm indicates that the transducer counts for TO1 and TO2 are off by five or six. This calculation is made after each axle crosses both gating transducers.

Continued on next page

System Alarm Definitions, Continued

Alarm	Definition
Highrange Transducer Miscounts Alarm	<p>The Highrange Transducer Miscounts alarm indicates that the transducer counts for TO1 and TO2 are off by seven or more. This calculation is made after each axle crosses both gating transducers. When this alarm occurs, the system won't announce axle count, exit speed, length of train, or total number of cars (even if these messages are enabled).</p> <p>The Highrange Transducer Miscounts alarm can be either a System Alarm or an Integrity Failure, depending on the presence of a Very Slow Train alarm. If a highrange transducer miscount occurs on a train that also contains a Very Slow Train alarm, the firmware treats the miscount condition as a System Alarm. This logic assumes that the train's slow rate of travel likely caused the transducer miscount condition. If a highrange transducer miscount occurs on a train traveling at a speed greater 7 mph (11.3 kph), the firmware treats the miscount condition as an Integrity Failure.</p>
Stuck Dragger Recovered Alarm	<p>The Stuck Dragger Recovered alarm indicates that a stuck dragger was detected during train passage and, at some point later, the dragging-equipment detector returned to its neutral position. After returning to its neutral position, the firmware must scan at least eight consecutive Dragger free axles before flagging this condition again.</p>
No Approach Track Alarm	<p>The No Approach Track alarm indicates that the track circuit (or the advance transducers) failed to signal the presence of a train and that the Sentry system started from the train passing over the gating transducers.</p>
Test Train Alarm	<p>The Test Train alarm indicates that a given train was generated by the Sentry system. These trains are used for testing purposes and do not represent actual trains passing the site.</p>

Integrity Failure Definitions

Overview This appendix describes the conditions and events that the Model 2100-950 Sentry System flags as Integrity Failures. These alarms indicate conditions in which the integrity of the system, and its ability to record train data accurately, may be compromised. These alarms are listed under the System Alarms section of the Train Detail and Exception Detail reports.

Failure	Definition
Dead Resistor Alarm	<p>The Dead Resistor alarm indicates the presence of two separate conditions. First, the train must contain a Cold Rail alarm on a given rail. Second, the recorded temperature for the resistor on that rail must fall below the cold-rail-alarm limit.</p> <p>There is a different Dead Resistor alarm for each rail. That is, there is a Dead North Resistor alarm and a Dead South Resistor alarm (or, depending on track direction, a Dead East Resistor alarm and a Dead West Resistor alarm).</p>
Successive Cold Rails Exceeded Alarm	<p>The Successive Cold Rails Exceeded alarm indicates that at least a preset maximum number of consecutive trains, all having Cold Rail alarms on the same rai1side, have passed a site. The maximum number (per rai1side) of consecutive trains having Cold Rail alarms allowed before generating this alarm is set by the Cold Rail option (of the Alarm Limits submenu of the Setup menu).</p> <p>Under normal circumstances, Cold Rail conditions represent System Alarms, not Integrity Failures. However, if the number of consecutive trains bearing the same Cold Rail alarm equals or exceeds the cold-rail-alarm limit <u>and</u> if the Announce Cold Rail option (of the Messages submenu) is set to YES, this condition becomes an Integrity Failure. If the number of consecutive trains bearing identical Cold Rail alarms equals or exceeds the cold-rail-alarm limit, the System Alarms section of the Train Detail and Exception Detail reports displays the message “Successive Cold Rails Exceeded.”</p> <p>A Successive Cold Rails Exceeded alarm is considered a System Alarm (not an Integrity Failure) if the Announce Cold Rail option (of the Messages submenu) is set to NO.</p>

Continued on next page

Integrity Failure Definitions, Continued

Failure	Definition
<p>Successive Cold Resistors Exceeded Alarm</p>	<p>The Successive Cold Resistors Exceeded alarm indicates that at least a preset maximum number of consecutive trains, all having Cold Resistor alarms on the same raii side, have passed a site. The maximum number (per raii side) of consecutive trains having Cold Resistor alarms allowed before generating an Integrity Failure alarm is set by the Cold Rail option (of the Alarm Limits submenu of the Setup menu).</p> <p>Under normal circumstances, Cold Resistor conditions represent System Alarms, not Integrity Failures. However, if the number of consecutive trains bearing the same Cold Resistor alarm equals or exceeds the cold-rail-alarm limit, this condition becomes an Integrity Failure. If the number of consecutive trains bearing identical Cold Resistor alarms equals or exceeds the cold-rail-alarm limit, the System Alarms section of the Train Detail and Exception Detail reports displays the message "Successive Cold Resistors Exceeded."</p>
<p>Successive Cold Wheels Exceeded Alarm</p>	<p>The Successive Cold Wheels Exceeded alarm indicates that at least a preset maximum number of consecutive trains, all having Cold Wheel Scanner alarms on the same raii side, have passed a site. The user determines the number of consecutive trains used in the comparison through the Cold Rails setup parameter.</p> <p>Under normal circumstances, Cold Wheel conditions represent System Alarms, not Integrity Failures. However, if the number of consecutive trains bearing the same Cold Wheel Scanner alarm equals or exceeds the cold-rail-alarm limit <u>and</u> if the Announce Cold Rail option (of the Messages submenu) is set to YES, this condition becomes an Integrity Failure. If the number of consecutive trains bearing identical Cold Wheel Scanner alarms equals or exceeds the cold-rail-alarm limit, the System Alarms section of the Train Detail and Exception Detail reports displays the message "Successive Cold Wheels Exceeded."</p> <p>A Successive Cold Wheels Exceeded alarm is considered a System Alarm (not an Integrity Failure) if the Announce Cold Rail option (of the Messages submenu) is set to NO.</p>

Continued on next page

Integrity Failure Definitions, Continued

Failure	Definition
Successive Cold Wheel Resistors Exceeded Alarm	<p>The Successive Cold Wheel Resistors Exceeded alarm occurs when a specified number of consecutive trains, each containing a Cold Wheel Scanner Resistor alarm on the same railside, pass the site. The user determines the number of consecutive trains used in the comparison through the Cold Rails setup parameter.</p> <p>Under normal circumstances, Cold Wheel Resistor conditions represent System Alarms, not Integrity Failures. However, if the number of consecutive trains bearing the same Cold Wheel Scanner Resistor alarm equals or exceeds the cold-rail-alarm limit, this condition becomes an Integrity Failure. If the number of consecutive trains bearing identical Cold Wheel Scanner Resistor alarms equals or exceeds the cold-rail-alarm limit, the System Alarms section of the Train Detail and Exception Detail reports displays the message “Successive Cold Wheel Resistors Exceeded.”</p>
Stuck Dragger Pretrain Alarm	<p>The Stuck Dragger Pretrain alarm indicates that the dragging-equipment detector was stuck before the scanners started scanning. That is, between the time of first receiving a pulse from the track circuit (or the advance transducers) and the time of first receiving a pulse from either gating transducers the Sentry system detected an open circuit from the dragging-equipment detector.</p>
Dead Battery Alarm	<p>The Dead Battery alarm indicates a float voltage of less than 18 volts on the standby batteries.</p>
Highrange Transducer Miscounts Alarm	<p>The Highrange Transducer Miscounts alarm indicates that the transducer counts for TO1 and TO2 are off by seven or more. This calculation is made after each axle crosses both gating transducers. When this alarm occurs, the system won’t announce axle count, exit speed, length of train, or total number of cars (even if these messages are enabled).</p> <p>The Highrange Transducer Miscounts alarm can be either a System Alarm or an Integrity Failure, depending on the presence of a Very Slow Train alarm. If a highrange transducer miscount occurs on a train that also contains a Very Slow Train alarm, the firmware treats the miscount condition as a System Alarm. This logic assumes that the train's slow rate of travel likely caused the transducer miscount condition. If a highrange transducer miscount occurs on a train traveling at a speed greater than 7 mph (11.3 kph), the firmware treats the miscount condition as an Integrity Failure.</p>

Continued on next page

Integrity Failure Definitions, Continued

Failure	Definition
Stuck Dragger During Train Passage Alarm	The Stuck Dragger During Train Passage alarm indicates that the preset maximum number of consecutive axles have had Dragging-Equipment alarms during train passage. The maximum number is determined by the firmware and is currently five.
Stuck High-Load Detector Pretrain Alarm	The Stuck High-Load Detector Pretrain alarm indicates that, before the scanners started scanning, the high-load detector was stuck. That is, between the time of first receiving a pulse from the track circuit (or the advance transducers) and the time of first receiving a pulse from either gating transducer, the Sentry system detected an open circuit from the high-load detector.
Stuck Wide-Load Detector Pretrain Alarm	<p>The Stuck Wide-Load Detector Pretrain alarm indicates that, before the scanners started scanning, the wide-load detector was stuck. That is, between the time of first receiving a pulse from the track circuit (or the advance transducers) and the time of first receiving a pulse from either gating transducer, the Sentry system detected an open circuit from the wide-load detector.</p> <p>There is a different Stuck Wide-Load Detector Pretrain alarm for each rail. That is, there is a Stuck Wide-Load Detector Pretrain North Side alarm and a Stuck Wide-Load Detector Pretrain South Side alarm (or, depending on track direction, a Stuck Wide-Load Detector Pretrain East Side alarm and a Stuck Wide-Load Detector Pretrain West Side alarm).</p>
Dead Wheel Scanner Resistor Alarm	The Dead Wheel Scanner Resistor alarm represents the wheel scanner equivalent of the bearing scanner's Dead Resistor alarm. For a given railside, Dead Wheel Scanner Resistor alarms occur when the recorded resistor temperature falls below the Cold Rail alarm limit and the train contains a Cold Wheel Scanner alarm on the same railside. Just like Dead Resistor alarms, separate Dead Wheel Scanner Resistor alarms exist for each railside
